

GLOBAL BID

COPY NO. _____

RS 10000/-



MUMBAI METROPOLITAN REGION DEVELOPMENT AUTHORITY

BID DOCUMENT

FOR

ERECTION OF STREET FURNITURE

IN

BANDRA-KURLA COMPLEX

ON

**DESIGN, BUILD, OPERATE, MAINTAIN & TRANSFER
(DBOMT) BASIS**

COPY ISSUED TO: M/s. _____

MARCH 2013

Joint Project Director (Town Planning)

MUMBAI METROPOLITAN REGION DEVELOPMENT AUTHORITY

Bandra-Kurla Complex, Bandra (East), Mumbai 400 051.

Tel: 022 2659 1435 Fax: 022 2659 5943

Email: shankardc1@gmail.com

Website: www.mmrda.maharashtra.gov.in

Name of Work:	ERECTION OF STREET FURNITURE IN BANDRA-KURLA COMPLEX ON DESIGN, BUILD, OPERATE, MAINTAIN & TRANSFER (DBOMT) BASIS
---------------	--

Officer In-charge (OIC):	Shri S.C. Deshpande Joint Project Director (Town Planning) Mumbai Metropolitan Region Development Authority Bandra-Kurla Complex, Bandra (East), Mumbai 400 051. Tel: 022 2659 1435 Fax: 022 2659 5943 Email: shankardc1@gmail.com
--------------------------	--

Notes:

1. The bidder is required to fill his offer after reading the bid document and making site visit to the prescribed locations of street furniture.
2. The bidder is requested to see the special conditions and attached drawings with specifications of work and make site visit before filing his offer.
3. Pre-bid meeting shall be held on 28th June at 3.00 p.m. in the Committee Room, 6th floor, MMRDA building, Bandra-Kurla Complex, Bandra (East), Mumbai-400 051.

SCAN DOCUMENT

Issued to:

M/s. _____

MUMBAI METROPOLITAN REGION DEVELOPMENT AUTHORITY (MMRDA)**BID DOCUMENT**

FOR

**ERECTION OF STREET FURNITURE IN BANDRA-KURLA COMPLEX
ON DESIGN, BUILD, OPERATE, MAINTAIN & TRANSFER (DBOMT)
BASIS****Table of Contents**

Chapter No.		Page No.
	Advt. issued in Newspaper	Photocopy
1	Instructions to Bidders	1 – 10
2	Form of Bid	11 – 12
3	Conditions of Contract	13 – 36
4	Form of Financial Offer	37
	ANNEXURE 'A' List of Street Furniture Items	38
	ANNEXURE 'B' Abbreviations & Definitions	39 – 41
	ANNEXURE 'C' Form of Contract Agreement	42 – 43
	ANNEXURE 'D' Specifications of Street Furniture Items	44 – 58
	ANNEXURE 'E' Locational Drawings	59-64
	Check list	65



MUMBAI METROPOLITAN REGION DEVELOPMENT AUTHORITY

Bandra-Kurla Complex, Bandra (East), Mumbai -51. Tel: 26590001/04. Fax: 91-022-26591264

Email: shankardc1@gmail.com Website: <http://www.mmrda.maharashtra.gov.in>

BID NOTICE FOR ERECTION OF STREET FURNITURE IN BANDRA-KURLA COMPLEX ON DBOMT BASIS – GLOBAL BID

Mumbai Metropolitan Region Development Authority (MMRDA) desires to undertake erection of State-of-the-art Street Furniture in E, G & G-N blocks of Bandra-Kurla Complex (BKC) and hereby invites bids on Design, Build, Operate, Maintain and Transfer (DBOMT) basis, against the advertisement rights thereon for concession period of 15 years.

Scope of work: The scope of work shall include Design, Build, Operate, Maintain and Transfer to MMRDA Street Furniture items like Benches, Litter bins, Information Boards, Direction Boards, Multipurpose Booths, Flag poles, Vending kiosks, Public Convenience, Bollards, Pole mounted CIP, Bus Queue Shelters, Tree Guards, Bicycle stands and Bicycles of International Standard as detailed in the Bid Document.

Eligibility Criteria:

- i. The agency must be eligible and competent to enter into contract under the 'Indian Contract Act 1872' and shall have office in Mumbai.
- ii. The agency shall have experience of Designing, Building, Operating and Maintaining minimum 50 % of each of the quantities of any of the 6 types of street furniture items, mentioned in the bid document within a city within a year in last 3 years.
- iii. Minimum 3 years of experience in the field of Outdoor Advertising on the above mentioned Street Furniture items is essential.
- iv. The minimum Annual turnover of the agency shall be Rs. 50 Crores for each of the last 3 years with minimum 25% turnover in fields of erection of street furniture and advertisement on Street Furniture.
- v. The agency shall submit valid Solvency Certificate of Rs. 10 Crores from any nationalized or Scheduled Bank preferably in Mumbai.

Note:

- i. The Bid Document can be obtained in person from the office of Joint Project Director (Town Planning), 2nd Floor, A wing, MMRDA between 11.00 AM to 05.00 PM on all working days from 3rd June, 2013 to 22nd July, 2013; on payment of Rs.10,000/- through D.D./Pay Order drawn in favour of 'MMRD Fund' payable at Mumbai accompanied by a request letter on the letterhead of the agency. The last date of submission is 03.00 PM on 31st July, 2013 and bids will be possibly opened on the same day at 04.00 PM. The pre-bid meeting shall be held at 03.00 PM on 28th June, 2013 at MMRDA office.
- ii. MMRDA reserves the right to accept or reject any or all bids without giving any reasons.
- iii. For any further clarifications please contact Shri. S.C. Deshpande, Joint Project Director (Town Planning) on Tel No. 022 2659 1435. The Bid Document is also available for reference on MMRDA website www.mmrda.maharashtra.gov.in

Date:28.05.2013

Place : Mumbai

(S.V.R. Srinivas, IAS)
Addl. Metropolitan Commissioner – (I)
and PD, MUTP



मुंबई महानगर प्रदेश विकास प्राधिकरण

वांद्रा-कुर्ला कॉम्प्लेक्स, वांद्रा (पु) मुंबई - ४०० ०५१
फोन ०२२-२६५९०००९/०४, फॅक्स ०९१-०२२-२६५९१२६४
ईमेल :- shankardc1@gmail.com वेबसाईट :- www.mmrda.maharashtra.gov.in

वांद्रा-कुर्ला संकुलात डि.बी.ओ.एम.टी (DBOMT) चा आधारावर स्ट्रीट फर्निचर उभारण्याकरिता निविदा सुचना - जागतिक निविदा

मुंबई महानगर प्रदेश विकास प्राधिकरण वांद्रे, कुर्ला संकुलातील ई, जी आणि जी-एन ब्लॉकमध्ये कलात्मक स्ट्रीट फर्निचर (DBOMT) डिझाईन - बील्ड - ऑपरेट - मेटेन आणि ट्रांसफर च्या आधारावर १५ वर्षांच्या जाहिरात कालावधीकरिता निविदा याद्वारे मागवत आहे.

कामाची व्याप्ती :-

सदर कामाच्या व्याप्तीनुसार संस्थेने निविदा दस्तावेजमध्ये नमुद केल्यानुसार प्राधिकरणाला DBOMT च्या आधारावर आंतरराष्ट्रीय दर्जाचे स्ट्रीट फर्निचर जसे की बेंचेस, लिटर बिनस, इन्फॉर्मेशन बोर्ड, डायरेक्शन बोर्ड, मल्टीपर्स बूथ, फ्लॅग पोल, वेन्डींग कियोक्स, पब्लिक कन्विनियन्स, बोलाई, पोल माउटेड सीआयपी, बस-क्यु शेल्टर्स, ट्री गार्डस, सायकल स्टॅंड्स इत्यादी उभ्या करण्याचा समावेश आहे.

पात्रतेसाठीचे निकष :-

- १) सदर संस्था इंडियन कॉन्ट्रॅक्ट अॅक्ट १८७२ खाली करार करण्यास पात्र व सक्षम असावी तसेच त्यांचे मुंबईमध्ये कार्यालय असावे.
- २) सदर संस्थेस निविदा लेखात नमुद केलेल्या स्ट्रीट फर्निचरमधील कोणतेही ६ स्ट्रीट फर्निचर आयटम पैकी प्रत्येकी ५०% स्ट्रीट फर्निचर DBOMT तत्वावर एका शहरात एका वर्षात उभारण्याचा मागील ३ वर्षांमध्ये अनुभव असावा.
- ३) वरील उल्लेखित स्ट्रीट फर्निचर संदर्भात सदर संस्थेला किमान ३ वर्षांचा बाह्य जाहिरातीकरण्याचा अनुभव असणे अत्यावश्यक आहे.
- ४) निविदा प्रस्ताव सादर करणा-या संस्थेची गेल्या ३ वर्षांतील वार्षिक किमान रु. ५० कोटी इतकी वार्षिक उलाढाल असावी व किमान ३५% उलाढाल ही स्ट्रीट फर्निचर उभारून त्यावर जाहिरात करण्याची असावी.
- ५) संस्थेने मुंबईतील राष्ट्रीयकृत अथवा अनुसूचित बँकेचे रु.१० कोटीचे पतदारी प्रमाणपत्र सादर करावे.

टिप्पणी :-

- १) निविदा दस्तऐवज व्यक्तिशः सह प्रकल्प संचालक (नगर रचना) दुसरा मजला, अ-ईमारत, मुं.म.प्र.वि.प्रा., वांद्रे-कुर्ला संकुल, वांद्रे (पुर्व) मुंबई-५१ येथे सकाळी ११.०० ते सांयकाळी ५.०० वाजेपर्यंत दि. ३ जून, २०१३ पासून दि.२२ जूलै, २०१३ पर्यंत कार्यालयीन कामकाजाच्या दिवशी खरेदीसाठी उपलब्ध असतील. निविदा दस्तऐवज रु.१०,०००/- इतक्या रक्कमेच्या "MMRDA Fund" नांवे काढलेल्या डी.डी./फे-ऑर्डर आणि त्यासह निविदा प्रस्ताव दाखल करणा-या संस्थेच्या लेटर हेडवर केलेल्या विनंती पत्र सादर केल्यावर मिळतील. निविदा दि.३१ जूलै, २०१३ रोजी दुपारी ३.०० वाजेपर्यंत स्विकारण्यात येतील व शक्यतो त्याच दिवशी सांयकाळी ४.०० वाजता निविदा उघडण्यात येतील. निविदा पूर्व बैठक दि.२८ जून, २०१३ रोजी दुपारी ३.०० वाजता प्राधिकरणाच्या कार्यालयात आयोजित करण्यात येत आहे.
- २) कोणतीही निविदा स्विकारण्याच्या अथवा कोणतीही निविदा रद्द करण्याचा अथवा सर्व निविदा कोणत्याही कारणाशिवाय रद्द करण्याचा सर्वाधिकार प्राधिकरणाने राखून ठेवलेला आहे.
- ३) वरील निविदेविषयी काही स्पष्टीकरण हवे असल्यास, श्री.शं.च.देशपांडे, सह प्रकल्प संचालक (नगर रचना) यांच्याशी दुरध्वनी क्र.०२२-२६५९१४३५ वर संपर्क साधावा. निविदा दस्तऐवज प्राधिकरणाच्या www.mmrda.maharashtra.gov.in या संकेतस्थळावर माहितीसाठी उपलब्ध आहे.

दिनांक : २९.०५.२०१३

ठिकाण : मुंबई.

(एस.व्ही.आर.श्रीनिवास, भा.प्र.से)

अति.महानगर आयुक्त-१

आणि प्रकल्प संचालक (सा.मा.वा.प्र.)

CHAPTER – 1

INSTRUCTIONS TO BIDDERS

ERECTION OF STREET FURNITURE IN BANDRA-KURLA COMPLEX ON DESIGN, BUILD, OPERATE, MAINTAIN & TRANSFER (DBMOT) BASIS

1. **Bandra-Kurla Complex (BKC):** Mumbai Metropolitan Region Development Authority (MMRDA) is the Special Planning Authority (SPA) for Planning and Development of Bandra-Kurla Complex comprising of E, G, and GN blocks; spread over 360 ha. in Bandra (East) of Mumbai. BKC is being developed as 'International Finance and Business Centre' (IFBC) of world standards and several prestigious Corporate Offices and Nationalized Banks are presently functioning from BKC. The Complex has State-of-the-art infrastructure. The Complex when fully operational shall have about 2 Lakhs jobs.
2. The Bid herein called by Mumbai Metropolitan Region Development Authority (MMRDA) is for Erection of Street Furniture Items in 'E', 'G', and 'GN' Blocks of Bandra-Kurla Complex, Mumbai on Design-Build-Operate-Maintain and Transfer (DBOMT) basis; as stipulated in the list enclosed and at the locations as shown in drawings enclosed with this bid subject on the conditions mentioned below and further subject to the 'Contract' annexed hereto. 'Instructions to Bidders', Form of Bid, 'Conditions of Contract,' 'Form of Financial Offer' and Annexure 'A' to 'E' are enclosed. You are requested to fill the bid and return the same in original to MMRDA duly signed on each page and certified, with the Earnest Money in the form of pay order/DD in favour of 'MMRD Fund' on or before the closing date.
3. The bidder shall read and understand all the terms and conditions before submitting the bid. All the work is to be carried out in accordance with this 'Bid Document' and as approved by OIC (Officer in Charge).
4. The Authority reserves the right to reject any or all the bids without assigning any reason thereof.
5. The Security Deposit shall be deposited as stipulated in 'Conditions of Contract'.
6. No alterations shall be made by the bidder in the contract, and if so made, his bid will be disqualified. The conditional bids shall be rejected. Any other information regarding the contract can be obtained from the OIC at the above address on any working day during the office hours.

7. The successful bidder has to erect Street Furniture items at his cost on specified locations or as approved by Officer In-charge (OIC) and offer Lump-Sum charges to be paid to MMRDA for concession period against the advertisement rights offered to bidder under this contract. Responsive bids shall be evaluated as mentioned in item 22 and 23.
8. If a claim for non-payment or underpayment of ESI Contribution (Employees' and Employer's) in respect of labour employed by the bidder is made by the ESI Corporation on the Authority, then it will be the Bidder's liability to make payment and indemnify the Authority and the Authority will be at the liberty to withhold any amount due to the bidder until it is satisfied that all amounts due under the ESI act are paid.
9. The Bidders are requested to inspect the spots of Erection of Street Furniture items mentioned in the Annexure 'A' and shown in the Annexure 'E' before submitting the bid. The Authority shall not be responsible for hindrance/obstruction, if any, to the display of the advertisement thereon or its non display due to any reason whatsoever beyond the control of the Authority once the contract is awarded. The number of Street Furniture items given in the Annexure 'A' may vary depending upon prohibition, if any, for displaying advertisement thereon by a competent statutory authority or any other reason. For such cases, item 16(c) of 'Conditions of Contract' shall apply.
10. **Bidder's Office and other details**
 - i. The Bidder shall have its office in Mumbai and shall be required to operate the contract from Mumbai.
 - ii. The Bidder should mention the name and address of the proprietor of the company. In case of partnership firm, name and address of the respective partners and in case of limited company, name and address of the Managing Director with supporting documents such as Memorandum and Articles of Association under the Companies Act and latest Annual Report of the company shall be provided.
11. **Financial Offer**
 - i. Financial offer must be submitted in 'Form of Financial Offer' failing which the offers are liable to be rejected.
 - ii. The financial offer amount should be in figures as well as in words preferably type written.

- iii. In case of divergence between offers in figures and words, the Offer given in words will be taken as correct amount.
- iv. All pages and all corrections made in the bid must be initiated by the bidder.

12. **Signature of bidder**

The 'Form of Bid' as in Chapter '2' and 'Form of Financial Offer' as in Chapter '4' must be dated and signed on each page by the Bidder. Any BID not so signed is liable to be rejected. The signature of the Bidder on the form of bid shall be construed as an acknowledgement on his part that he has acquired all the information in order to quote his financial offer.

The signature of the Bidder (who is later declared as successful) on the 'Form of Bid' shall also be construed as if the Bidder has entered into a binding agreement with the Authority on the terms and conditions stated in the form of bid till he signs the contract/agreement documents and he shall abide by all the conditions of contract.

13. **Commencement and Concession period**

Date of commencement of contract shall be mentioned in the Work Order to the Contractor hereinafter known as the Agency and the period of concession shall be 15 years from date of work order.

Depending upon the performance of the Agency, MMRDA reserves the right at its sole discretion to extend the contract by such period, not exceeding 5 years, on the same terms and conditions mentioned in this bid.

14. **Earnest Money**

- i. Every BID must be accompanied by Earnest Money Deposit of Rs. 50 Lakhs (Rupees Fifty Lakhs only) to be paid by Demand Draft / Pay Order drawn in favour of the "MMRD FUND" and payable at a Schedule Bank in Mumbai.
- ii. The Bidder should mention the receipt number and the date in the column provided for this purpose in the 'Form of financial Offer'.
- iii. No bid will be considered unless the Earnest Money is paid along with the bid.
- iv. No interest will be payable on this Earnest Money Deposit.
- v. The Earnest Money deposited by the unsuccessful Bidders will be **refunded only** after the expiry of the validity period of **the bid i.e. 180 days** after opening of financial offer.

- vi. The Earnest Money will be forfeited
 - a. If the bid is withdrawn after the closing and before the expiry of the last date of the period of validity mentioned in bid.
 - b. If the successful Bidder fails to deposit the Security Deposit as mentioned in the 'Conditions of Contract'.
 - c. If it should at any time be discovered that the Bidder has submitted more than one bid under different names, all his bids will be rejected or agreement cancelled and Earnest Money and/or Security Deposit forfeited.
 - d. Any attempt made to influence anyone for the award of contract will disqualify the Bidders.

15. Acceptance of bid

The right of acceptance of bid will rest with the Competent Authority of MMRDA, which does not bind itself to accept the bid with highest composite score or any bid and reserves to itself the authority to accept, amend, modify, negotiate and/or to reject at any time any or all the bids received at its sole discretion without giving any reasons therefor and without any cost to MMRDA.

16. Eligibility Criteria of the bidders

The acceptance of the bid shall be governed by the 'Conditions of Contract' hereto attached. The Bidder shall submit the documents to MMRDA satisfying the following minimum eligibility criteria. Joint Ventures are not allowed,

- i. The bidder must be eligible and competent to enter into contract under the Indian Contract Act, 1872 and shall have office in Mumbai. Outstation agencies shall be eligible for participation in the bid if they agree to open there office in Mumbai if the bid is awarded to them.
- ii. The bidder shall have experience of Design, Build, Operate and Maintaining minimum 50% of each of the quantities of any of the 6 types of street furniture items, mentioned in Annexure A; within a city within a year in last 3 years.
- iii. The bidder shall have Minimum 3 years of experience in the field of Outdoor Advertising on Street Furniture items mentioned in Annexure A is essential.
- iv. The bidder shall have the minimum Annual turnover of Rs. 50 Crores for each of the last 3 years with minimum 25% turnover in fields of erection of street furniture and advertisement on Street Furniture.

- v. The bidder shall submit valid Solvency Certificate of Rs. 10 Crores from any nationalised or Scheduled Bank preferably in Mumbai.

17. Validity

The offers submitted shall remain valid for acceptance for a period of **180 days** from the date of opening of the Financial Offer.

- 18. Addenda/Corrigenda to the bid document and Minutes of the Pre-Bid Meeting, if issued by MMRDA shall be part of a bid document and it shall be signed, initialled and submitted by the Bidder along with bid document.**

19. Submission of Bids

The bidder shall provide self certified copies of all the documents as prescribed in item 16. Those bidders not submitting the required information and documents as specified in item 16 are liable for rejection and shall be treated as non responsive. Also, Bidder shall submit its concept, theme, design, drawings and specifications (material, size, shape, make, fixing details, etc.) of street furniture items to be proposed; specifying clearly area for advt. display (if any) not exceeding overall advt. area as specified in Annexure 'D' as a part of Technical proposal. Further to this, bidder shall provide implementation, operation and maintenance plan to be adopted for the project.

- Envelope 'A' i.e. Technical Proposal shall contain Earnest money, documents justifying Eligibility criteria and detailed design information as mentioned above and shall be opened first.
- Envelope 'B' i.e. Financial offer shall be opened only of those bidders who qualify in Technical proposal.
- Envelope 'C' containing both the envelopes (Envelope 'A' with Technical Proposal and Envelope 'B' with Financial Offer) shall be submitted to the MMRDA; sealed and duly superscribed with the words "Bid for Erection of Street Furniture in Bandra-Kurla Complex, Mumbai on DBMOT basis" and addressed to the Joint Project Director (Town Planning), Mumbai Metropolitan Region Development Authority (MMRDA), 2nd Floor, Bandra-Kurla Complex, Bandra (East), Mumbai - 400 051.

Refer Check list attached with this document for submission method to be adopted.

20. Last date of Submission

Bids shall be deposited in the sealed Bid Box in office of the Joint Project Director (Town Planning) at the address mentioned above latest by 3.00PM on 31st July 2013.

Bids received after the aforesaid hours and date shall be rejected.

Bids shall not be sent/ received by Post/Courier etc. Bids shall be accepted in person only.

21. Opening of Bids

Bids shall be opened, if possible, at 04.00 p.m. on the same date i.e. 31st July 2013 at the office of the Joint Project Director (Town Planning), 2nd Floor, Bandra-Kurla Complex, Bandra (East), Mumbai or at any other location as decided by MMRDA in the presence of such bidders who may desire to be present.

A bid not in compliance with the aforesaid conditions is liable to be rejected.

22. Selection of Preferred Bidder**i. Stage I: Evaluation of Technical proposal :**

- a. EMD: As per the criteria set out in item 14 of 'Instructions to Bidders'.
- b. Eligibility Criteria: As per the criteria set out in item 16 of 'Instructions to Bidders'.
- c. Documents for Design Information: As per the evaluation parameters mentioned in item 23 (i).
- d. Those bidders who secure Technical Score of 70 and above shall qualify for evaluation of financial bid.

ii. Stage II: Evaluation of Financial Offer:

Qualified bidders in Stage I shall be evaluated on the basis of the evaluation criteria as mentioned in item 23 (ii).

iii. Stage III: The composite evaluation of the Technical proposal and the Financial Offer would be carried out as set out in item 23 (iii).**iv. Stage IV: The bidder securing highest composite score shall be successful bidder. However, MMRDA reserves the right to accept or reject the proposal of the Bidder with highest composite score.**

23. Evaluation Parameters

i. Technical Offer (Envelope A)

- a. EMD and eligibility criteria shall be evaluated as per the minimum requirement set out in the bid. However, the design Information submitted by bidder shall be evaluated by MMRDA based on the following parameters/ MMRDA design committee constituted by MMRDA shall grant marks based on the documents/presentations submitted/made by bidder to substantiate the below parameters:

Sr.	Evaluation Parameter	Evaluation Elements	Max. Marks
A	Eligibility Criteria		
(a)	Experience of Design, Build, Operate, Maintain	All street furniture items within city for more than 3 years	10
(b)	Experience of Outdoor Advertisement on street furniture items	Experience of advertisement on all street furniture items more than 53years	05
(c)	Annual turnover	Annual turnover more than 50 Cr. for last 3 years and more than 25% turnover in fields of street furniture advertisement	10
	Eligibility criteria (A)		25
B	Design Criteria (Refer Annexure D)		
	The bidder shall submit designs of Street furniture items mentioned in Annexure D. The bidder shall submit scaled drawings on A3 size paper in the form of plans, sections, elevations, 3D perspectives, etc. to understand the design with specifications, materials, fixing details, advt. area, etc. for each of the item. Along with the drawings the bidder shall submit following information for each of the item. Multiple designs of an item can be submitted along with separate information as follows:		
(a)	Functional	Does it seem to meet the functional requirements?	5.0
(b)	Maintainability	<ul style="list-style-type: none"> Is it likely to require lesser maintenance? Is it likely to be easier and/or cheaper to maintain? 	2.5
(c)	Vandalism-proof	Does the design seem to be vandalism proof?	2.5
(d)	Security & Safety Considerations	Does it appear that the security & safety considerations have been given due attention?	2.5
(e)	Durability	<ul style="list-style-type: none"> Does it appear to be durable? Is it likely to require less frequent replacement? 	2.5
(f)	Aesthetics	<ul style="list-style-type: none"> Does the design appear to be appealing? Does it look good? Is it likely to enhance the beauty of the street and its 	10

Sr.	Evaluation Parameter	Evaluation Elements	Max. Marks
		surroundings?	
(g)	Co-ordinated design of the various items	<ul style="list-style-type: none"> Does it appear that the various street furniture items have been designed in a cohesive and coordinated matter? Do the items appear related and seem to belong to a family?	2.5
(h)	Innovativeness	Does it seem that the design brings in an element of innovation?	5.0
(i)	Modularity	<ul style="list-style-type: none"> Is the design modular? Is it convenient to reduce or expand the size/capacity?	2.5
(j)	Environment Considerations	Does it appear that the environment considerations have been given due attention?	2.5
(k)	Disable Friendliness	Does the design seem to be disable-friendly?	2.5
	Design Criteria (B)		40
C	Implementation Plan The bidder shall submit Bar chart, Flow chart, etc. to substantiate implementation schedule of 12 months. With following details: Procurement /Construction Plan To what extent does it seem that the Implementation Plan has been well thought out and practical with regard to the following: <ul style="list-style-type: none"> Schedule of Activities / Bar Chart Organisation Phases of implementation Procurement planning Installation planning Quality Assurance Plan Environment management Safety management Labour planning Supervision Traffic & Circulation Plan		10
D	Operation & Maintenance Plan The bidder shall submit Operation and Maintenance Plan for whole concession period with following details:		
(a)	Operation Plan	To what extent does it seem that the Operation Plan has been well thought out and practical with regard to the following: <ul style="list-style-type: none"> Operational Activities Organisation structure of the operational team Equipment & Resources at the disposal of the operational team Monitoring and reporting mechanism	10
(b)	Maintenance Plan	To what extent does it seem that the Maintenance Plan has been well thought out and practical with regard to the following:	15

Sr.	Evaluation Parameter	Evaluation Elements	Max. Marks
		<ul style="list-style-type: none"> • Details of the preventive/periodical maintenance and break down maintenance proposed to be carried out • Maintenance Schedule containing activities and periodicity • Organisation structure of the maintenance team • Equipment & Resources at the disposal of the maintenance team Monitoring and reporting mechanism 	
Operation & Maintenance Plan (D)			25
Total Max. Marks (A+B+C+D)			100

- b. The Bidder who will secure maximum marks shall be given a Technical Score out of 100 marks. The relative Technical scores of other Bidders for the Project shall be computed as follows:

$$\text{'Technical Score' of Bidder for the Project (X)} = 100 \times \frac{\text{Marks secured by the respective bidder}}{\text{Highest Marks secured}}$$

- c. The score secured based on evaluation of the Technical Bid as above shall be the 'Technical score' of the Bidder for the Project being considered for evaluation. (X)
- d. Only those Bidders who have secured 'Technical Score' of 70 marks or above shall be declared as qualified for evaluation of their Financial Bid.

ii. **Financial Offer (Envelope B)**

- a. The Bidders shall submit their quote as per the format provided in Chapter 4 ("Financial Offer").
- b. The Financial offers shall be evaluated on the basis of Total Lump-Sum charges offered by the bidder to the Authority against the Advertisement Rights assigned to him during the concession period for the Project.
- c. The Financial offers of the qualified bidders (who have secured Technical Score of 70 marks or above) shall be tabulated for Project and the Bidder whose Financial Offer has the highest "Concession Fee" to be payable to the Authority for the Project during the concession period shall be given a Financial Score of 100 marks. The financial scores of other bidders for the Project shall be computed as follows:

$$\text{'Financial Score' of bidder for the Project (Y)} = 100 \times \frac{\text{Concession Fee quoted by the respective bidder for the Project (₹)}}{\text{Highest Concession Fee quoted for the Project (₹)}}$$

d. The marks secured as above shall be the 'Financial Score' of the Bidder for the Project.

iii. **Composite Score of the Bidders**

Composite Score of the Bidders for a Project shall be worked out as under: The weightage to Technical score should be 70% and Financial score shall be 30%.

Bidder	Technical Score (X)	Financial Score (Y)	Weighted Technical Score (70% of X)	Weighted Financial Score (30% of Y)	Composite Score (F=D+E)
A	B	C	D	E	F
1					
2					
3					

iv. **Special Conditions for Evaluation**

The Successful Bidder shall be the person securing highest Composite Score in column 'F' above. However, in the event that two or more Bidders secure exactly the same Composite Score, then MMRDA reserves the right to:

- a. declare as Successful Bidder that bidder whose Technical Score is highest, among such Bidders who have secured exactly the same Composite Score, or
- b. invite fresh financial Proposals from these Bidders having same composite scores and evaluating these financial proposals, or
- c. splitting/ amalgamating the project and items to the bidders having same composite scores; as decided by MMRDA, or.
- d. Adopt any other method as decided by Metropolitan Commissioner MMRDA.

CHAPTER – 2

FORM OF BID

To,

The Joint Project Director,
Town Planning,
2nd floor, MMRDA Building,
Mumbai Metropolitan Region Development Authority,
Bandra-Kurla Complex,
Bandra (East), Mumbai – 400 051.

Ref: BID No. JPD/SF/2013

Sub: Erection of Street Furniture in Bandra-Kurla Complex on Design, Build, Operate, Maintain and Transfer (DBOMT) basis

Respected Sir,

We hereby offer to execute the above mentioned contract for the erection of Street Furniture Items at our cost and display of advertisement on them in 'E', 'G', and 'GN' blocks of Bandra-Kurla Complex as per the Conditions of Contract of MMRDA by paying the amount quoted by us in the 'Form of Financial Offer' which is enclosed herewith duly completed, signed and sealed by us.

We have examined the spots where Street Furniture Items are to be erected; and we agree with all the conditions of Contract and we have also taken into consideration the nature of the work and the conditions under which it is to be carried out, before submitting this bid.

We do hereby undertake to display the advertisement on Street Furniture Items only after obtaining the necessary permissions/ NOC from all the concerned Statutory Authorities, and offer paying necessary charges/fees/ deposits etc.

We have paid the Earnest Money Deposit vide Receipt No. _____ dated _____ in favour of 'MMRD Fund'. We do hereby agree that this sum of EMD shall not bear any interest and this sum shall be forfeited by the Authority, subject to Clause 14 (vii) of Chapter-I – Instructions to Bidder.

We hereby agree to pay Security Deposit as per bid conditions.

In the event of non-display of any advertisement due to damage or breakage of the advertisement board or removal of the Street Furniture item for any reason beyond the control of the Authority or for any reason whatsoever, we shall have no

claim of whatsoever nature against the Authority for non-display of the advertisement.

We shall not claim any shifting charges of the erected Street Furniture items, required to be shifted in larger public interest or as directed by MMRDA.

No claim for compensation for loss of profit or otherwise shall be raised by us.

We declare that our offer is valid for a period of **180 days** from the date of opening of Financial Offer.

We declare that if a claim for non-payment or under payment of ESI Contribution (employees and employers) in respect of labour employed by us is made by the ESI Corporation on the Authority, then it will be our liability to make payment and we indemnify the Authority and the Authority will be at liberty to withhold any amount due to us until it is satisfied that all amounts due under the ESI Act (latest amendment) are paid.

We understood the fact that signing the 'Form of Bid shall be construed as we have entered into the binding agreement with the Authority on all the terms and conditions stated in the bid booklet till we sign the contract/ agreement documents.

We shall indemnify MMRDA from any legal disputes arising on site.

We do hereby submit our bid at our own free will.

Yours faithfully,

Date: _____

(Signature of the Bidder)

Name of Bidder: _____

Add. for correspondence: _____

Tel No: _____ Fax No. _____

Mob No. _____

E-mail: _____

Note: The Bidder shall fill in the blanks and sign the documents with seal of the signatory.

CHAPTER – 3

CONDITIONS OF CONTRACT

ERECTION OF STREET FURNITURE IN BANDRA-KURLA COMPLEX ON DESIGN, BUILD, OPERATE, MAINTAIN & TRANSFER (DBMOT) BASIS

1. Scope of Contract

- a. This contract is for erection of Street Furniture items in Bandra-Kurla Complex on Design-Build-Operate-Maintain-Transfer basis; as per the quantities mentioned in Annexure A, specifications mentioned in Annexure D and at locations mentioned in Annexure E of this bid or as approved by OIC against the display of advertisement on Street Furniture items mentioned in the design and drawing of Street Furniture items and subject to approvals of all statutory authorities after due payment to all such authorities. It also includes paying the authority a sum of display charges as per the 'Form of Financial Offer'. The Construction Period of Street Furniture items shall be **365 days** and in phases from the date of Work Order. Phase -I (construction period before 180 days) shall include entire E block and 45 m road in G block. Phase -II (construction period before 270 days) shall include balance roads in G block. Phase -III (construction period before 365 days) shall include G - n Block. However, the bidder is at liberty to complete Phase -II and III along with Phase I and or before 180 days for which he will receive bonus as mentioned below.
- b. The designs, specifications and locations provided by MMRDA are only for indicative purpose only. This shall act as minimum bench mark. The bidder shall propose innovative, aesthetic state of the art designs which are environment friendly, structurally safe, durable for at least 20 years, rust proof and which gel with the overall urban built form of BKC. However, the maximum total advertisement display area shall remain unchanged. The bidder also has liberty to propose advertisement on any other items subject to total maximum advertising area remaining unchanged and subject to approval by MMRDA.
- c. The concession period shall be for 15 years including the construction period. The probable date of Work Order shall be 01st October 2013. MMRDA reserves the right to extent the concession period by another 5 years on the same terms and conditions.

b. Bonus V/s Penalty

For completion of entire construction of all the street furniture items before end of 365 days the display will be allowed from the date of completion and no premium fees for this pre-completion period will have to be paid to Authority and will act as bonus to the Bidder. However, display shall be allowed after satisfactory completion of all Street Furniture items, and after obtaining Completion and Electricity Certificate from PWD/ Certificate from certified Electrical Engineer, submitting Structural Stability Certificate to MMRDA and compliance of all statutory approvals. If the bidder exceeds the construction period, than the premium shall be payable by the bidder from the 365th day irrespective of the advertisement display and erection of street furniture. However the genuine delay beyond the control of bidder can be condoned by MMRDA if duly justified by the bidder. However the decision of MMRDA shall be final and binding.

The Agency, may, as per the design, proposed by him, display the advertisement of any product/company of the Street Furniture item; as per the specifications mentioned in Annexure D and not exceeding the overall advt. area as specified. While submitting the drawings for approval to the OIC, the Agency shall clearly mark the proposed space for advertising. After approval from the OIC, the Agency shall also take prior approval from other Concerned Authorities as may be required. The bidder shall submit dimension drawing (top), plan, section, elevation, 3 D perspective, colour drawing, with specifications, material, advertisement area, etc on A4/ A3 size paper.

The Agency shall not be allowed to display advertisement on Street Furniture items unless and until the Security Deposit referred to in Clause No. 18 of 'Conditions of Contract' is paid to the Authority vis-à-vis before obtaining the necessary permissions/NOC from the MCGM or other concerned statutory authorities and after paying the necessary charges to the concerned authorities.

- c. The Agency shall obtain approvals from all the statutory authorities concerned necessary for display of advertisement on Street Furniture Items and its illumination. The Agency shall submit such approvals / NOC's to the OIC. All the charges for obtaining approval / NOC's from statutory authorities shall be borne by the Agency.

- d. The successful Bidder is bound by the terms and conditions of this contract, to display advertisement on Street Furniture Items mentioned in the Annexure 'A' and Annexure 'E'

- e. **Financial Offer**

The Bidder has to offer Lump sum premium fees/display charges to be payable to MMRDA for the concession period in form of financial offer against the advertisement rights offered to him under this contract. The entire amount quoted shall be divided into equal monthly installments to be paid in advance of each month. (Please refer clause no. 16 of 'Conditions of Contract'.)

- g. The Agency shall not be permitted to carry out any addition / alteration in the locations/specifications of Street Furniture Items once approved in the contract. However, the Agency may propose an alternative location/specification better than that given in the bid documents (specifications, materials and improved facilities for pedestrians) for any or all of the Street Furniture Items, if so desired, for evaluation to the Design Committee/ MMRDA. MMRDA reserves the right to accept such change proposed by bidder without change in overall Advt. area of the project. No claim for compensation of whatsoever nature including reduction in display charges will allowed against reduced display areas, if any. The newly constructed Street Furniture items shall be the property of this Authority and will be handed over to MMRDA after end of concession period and in proper functional order.

- 2. **Removal/shifting of Street Furniture Items and advertisements on them**

- a. The Agency shall alone be responsible for the display of advertisement on Authority's Street Furniture Items. The Agency shall submit complete details of the framework proposed for advertisement for the perusal of OIC. The Agency shall comply with the directions / instructions of the OIC in respect of the said arrangement. The Agency shall also comply with the directions / instructions of the representative of Joint Project Director (Town Planning), owner's Representative of the project if and when deputed to the site for supervision.
- b. The Agency should attend the complaints pertaining to the Street Furniture and the advertisement provided on them within 3 days from the receipt of such letter issued by OIC from time to time. All expenses connected with such complaints including removal/shifting of Street Furniture items or advertisements; maintenance of Advertisements etc, if any, shall be borne by the Agency.

- c. If at any time during the continuance of the contract, any Authority duly empowered or authorised in that behalf by OIC requests for any reason including road widening, concreting/ Public utility shifting/ repair etc. to remove the Street Furniture items or advertisement on Street furniture items, the Agency on prior intimation from the Authority shall remove such item and/or the advertisement displayed on it at their own expense forthwith. If the Agency shall make default in such removal after notice to that effect has been served upon them by the OIC within the time period stipulated in the notice, then the OIC shall be at liberty to effect such removal at the risk and cost of the Agency without the Agency becoming entitled to any compensation in respect thereof and in that case clause no. 13 shall apply. In addition to this the Agency shall be liable to pay **the penalty/charges equal to Rs. 10,000/- (minimum) per Street Furniture item.** The Agency shall be entitled to take back the said material from the Authority within a period of **15 days** from the date of intimation to the Agency to that effect after which such materials would become the property of the Authority and the Agency shall have no claim of whatsoever nature on them.
3. **Erection & Maintenance of Advertisement**
- a. The Agency shall maintain the Street Furniture items' illumination on and public facilities in a proper and usable manner in accordance with technical specifications. The Agency shall bear all costs incurred for display of advertisement on Street Furniture items and shall carry out the work of fixing and removing the same in a careful manner without doing any damage to the Street Furniture items and the adjoining property. If any damage is caused to the same, it shall be made good by the Agency at its own cost to the entire satisfaction of the OIC. The Agency shall maintain the advertisement along with the framework, if any, in good condition and likewise ensure that the display of advertisement thereon is in a proper and perfect condition. The Agency shall immediately on receiving notice from the OIC make good at their own expense the default / fault in the Street Furniture item/ advertisement with the structure to the entire satisfaction of the OIC within seven days from the date of receipt of such notice, failing which the Authority shall be at liberty to proceed with the work required to be carried out at the risk and cost of the Agency without any further notice to them as stipulated in Clause No. 13 appears herein after.

- b. While the Street Furniture items or advertisements are being fixed or removed or re-fixed by the Agency, it shall take all necessary safety precautions and if any damage is caused to or is suffered by a person or property of the Authority or by any third party due to any cause whatsoever, the Agency shall be solely responsible for compensation or damage to the Authority's property or the third party as the case may be and the Agency shall indemnify and keep the Authority indemnified in respect of any claim made thereunder.
 - c. MMRDA shall not be liable to pay any compensation in case the Agency, their servants, agents or any other person meet with an accident or in case any injury is caused to or suffered by any one of them or by any third party or to any property whatsoever while the work under the contract is undertaken by the Agency. The Agency shall keep the Authority indemnified in that respect. The agency shall be responsible for structural safety of the Street Furniture items and indemnify MMRDA for any damages. The agency shall cover the street furniture items under insurance policy as specified in item 4.
 - d. The Agency shall not carry out any addition or alteration to the any of the Street Furniture items unless; it is approved by the OIC.
4. **Illuminated Advertisement**
- a. The Agency shall be permitted, subject to power cut and / or any other restrictions and / or other rules in force, which are beyond the control of the Authority to display illuminated advertisement on those Street Furniture items that are mentioned in the Annexure 'D' and 'E'. However, due to non-availability of power supply for any reason, no claim of any sort would be entertained in this regard. **No separate payment will be charged from the Agency for illuminating the advertisement.** The installation work including electrification should be done by the Agency. The structure / design should have prior approval of the OIC the electricity bills for such illumination should be paid by the Agency directly to the concerned authorities. The electrical installation including earthing of all metallic parts, provision of ELCB etc. shall be in accordance with the provisions of the Indian Electricity Act, 1910 and Indian Electricity Rules and the approved plan. All external and internal wiring cables, fittings including service cables and provision of Meter Box, etc. required for illumination of Street Furniture Items/advertisements shall be procured and laid by the Agency at its own

cost using the ISI approved materials and as per Standard Specifications. The Agency shall provide/ install the electric meter box at appropriate height, so that it should not obstruct the commuters/ pedestrians. No additions or alterations should be made without prior approval of the Authority. The illuminated advertisement to be constructed/put up should be completely waterproof, so that no water enters inside and damages electrical wires, etc.

The Agency shall protect the electric installation and shall arrange to maintain it in good and safe working condition by way of periodical checking (at least every 3 months) and renew it as and when necessary with the approval of the Statutory Authorities concerned as the case may be. The bidder shall obtain Electricity safety Certificate for all installed Street Furniture items with Electricity from PWD/ Certified Electrical Engineer every year and submit to MMRDA along with the Structural Stability Certificate obtained from the Certified Structural Engineer.

- b. The maintenance of illuminated advertisement shall also be the responsibility of the Agency. The Agency shall carry out the work pertaining to the fixing, maintaining and removal of illuminated advertisements at its own cost. The Agency shall be wholly responsible for compensation or damages in case of damage to any property, lives of the person of Authority or public due to display of the illuminated advertisements including electric shock and fire due to short-circuit, etc. In such cases, the amount of compensation assessed by the Authority shall be final and binding on the Agency. On the expiry of contract period, the Agency shall arrange to disconnect the electric supply including pot heading of electric cable and reinstatement work etc. wherever illuminated advertisement has been displayed.
- c. The Agency shall ensure that illumination is done in such a way that it does not cause any nuisance to the vehicle drivers on the road or to the residents in the vicinity. Any objection raised in this respect shall be rectified / removed by the Agency immediately at its own cost. The use of Generators for illuminating advertisement would not be permitted under any circumstances. However, if at any time the Generator Sets are found installed for illuminating advertisement, the same would be removed at the risk and cost of the Agency without any intimation to him as stipulated in Clause No.13 appears hereinafter.

- d. It will be the Agency's sole responsibility to pay the charges, rents, taxes, electricity bills deposits on etc. levied by the Concerned Authorities directly to the authorities concerned.
- e. It shall be the sole responsibility of the Agency to obtain all necessary permissions from the Statutory Authorities required for illuminating the advertisement and obtaining power supply under intimation to the OIC.
- f. The glare factors should be so defused that it does not create any nuisance to the eyes of the road users / commuters.
- g. No Traffic light colours i.e. red, green and amber should be used for the illumination of the advertisement.
- h. If at any time it is found / noticed /or brought to notice that the Agency has drawn electric supply unauthorisely to illuminate advertisement over any Street furniture item, then the Agency shall be liable to pay on demand the electricity charges and / or penalty as computed by the Authority / Reliance Energy / MSEB or any other competent authority.
- i. The Agency shall strictly follow the provisions (amended from time to time) of the Bombay Electricity (Special Powers) Act 1946 under which at present, the use of electrical energy for the purpose of lighted (illuminated) hoardings and bill boards **for more than five hours in a day is prohibited subject to such use or consumption shall not be permissible beyond mid-night.**

5. **Urgent Removal of Street Furniture item or Advertisement thereon**

If any street furniture item(s) or advertisement(s) is required to be shifted or removed urgently due to accidents, act of God, thefts, or on the direction of concerned Statutory Authorities before the expiry of contract period for any other reason whatsoever, the said item or advertisement displayed on it shall be removed by the Agency with their cost forthwith **within twenty four hours on receipt** of telephonic / written instructions by OIC to that effect. In case of failure to do so the Authority will arrange to have the same removed at the risk & cost of the Agency. No compensation in that respect will be payable to the Agency. They shall be, however, liable to **pay the charges incurred for removing/ shifting the item or advertisement.** The Agency shall collect the materials from the Authority's premises within **15 days** from the date of receipt of intimation to them to that effect.

6. **Accident and Damage to Street Furniture item and Advertisement thereon**

MMRDA shall not be responsible or liable to compensate the Agency for any theft or loss or damage, wear and tear of the Street Furniture item or advertisement on it or for non-display of advertisements due to the said damage, breakage etc, if any, for any reason whatsoever during the period of contract. MMRDA shall also not be responsible for disfigurement of or detriment to the Street Furniture item or advertisement due to pasting of paper posters or any other material thereon or due to any other reason whatsoever. The Agency shall not claim any rebate including reduction in display charges against the Authority for non-display of advertisement and removal of Street Furniture item on such account, during the contract period. The agency shall indemnify MMRDA for any litigations, claims, suits, disputes, damages etc.

7. In case of damage / accident to Street Furniture Items or the advertisement thereon; it shall be removed/ rectified by the Agency immediately from the date of intimation from the Authority to that effect. On failure of the Agency to do so in seven days or as intimated by OIC the same would be got done by the Authority at the risk and cost of the agency.

8. **Approval of advertisement matter / objectionable advertisement**

Before the display of the advertisement, the Agency shall in the first place submit the text of advertisement matter, art work etc. of each display for the approval of the competent Authority.

The display of advertisement, designs, materials and positions for all advertisement shall be subject to the approval of the OIC.

The Agency shall not display advertisement propagating Cigarettes, Bidis or any other type of Tobacco or its product, alcohol or other intoxicant products. The Agency shall also not display advertisement related to awareness about HIV / AIDS unless permitted/approved by Public Health department, Govt of Maharashtra and screened by the MCGM in order to ensure that the advertisement does not impart an anti-women message. Similarly the Agency shall not display advertisement which imparts any message against any individual, group, class creed, religion and race.

Further, no advertisement shall be displayed which, in the opinion of the OIC offends any law or religion or public morality or is defamatory or the display whereof is prohibited by any lawful authority or is against the interest of the MMRDA.

No unsightly, indecorous or objectionable advertisement shall be displayed at any site under this contract and the decision of the competent authority as to what is unsightly, indecorous or objectionable within the meaning of this Clause shall be final and binding upon the Agency. Upon the OIC requiring the Agency to remove any such advertisement, the Agency shall forthwith remove the display thereof without any dispute / claim. No advertisement with the use of the name or pictorial representation of any national figure or emblem prohibited by law shall be displayed by the Agency. During the period of contract, if on any ground any advertisement is/are objected to by any Competent Authority or if the advertisement is objectionable in anyway as stated above, then the Agency shall remove/ deface the said advertisement within 24 hours on receipt of verbal/ written instructions to that effect. On failure of the Agency to do so, the same would be removed/ defaced by the Authority at the risk & cost of the Agency and the Agency shall not be liable for any compensation. The agency shall indemnify MMRDA for any disputes arising out of the contents, location, illumination, timings, display of advertisements displayed by him.

9. **Erection of Street Furniture items: Specifications**

The Street Furniture items erected by agency shall comply with all the minimum specifications mentioned in this bid.

The agency shall have to produce the manufactures warranty certificate for the items used for manufacturing of the Street Furniture items as instructed by the OIC & shall have to get the structural drawings prepared at their own cost from a licensed Structural Engineer as per site conditions & obtain structural stability certificate from him. The said structural designs have to be got certified from the Authority. The bidders shall produce evidence to conformity of all materials used for Street Furniture items to Indian standards or to International standards. After erection of Street Furniture items structural engineer shall certify the same for stability and occupation and such certificate shall be given every one year or within 1 week of the rectification of the damage done if any. The Authority shall demand any tests on the materials used and the same shall be complied by the agency at agency's cost. After submission of such Structural Stability Certificate and upon complete satisfaction of OIC, OIC shall issue NOC for operation of the Street Furniture item and display of advertisements thereon.

10. The Agency shall be permitted to display advertisements on the Street Furniture items in the space reserved for the advertisement thereon and approved by OIC. The advertisement space shall form an integral part of Street Furniture item.

11. **Specifications of the Advertisement Boards**

The Agency shall be responsible for the observance of the rules and regulations laid down or as may be laid down thereafter from time to time by the MCGM in this behalf and other statutory Authorities.

12. **Use of Advertisement Spaces for Public Interest**

The Authority reserves the right to itself to use Advt. Area of the Street Furniture items not exceeding 2% of the total advt. area for display of advertisement free of charge for whole concession period in the interest of the Authority, Municipal Corporation of Greater Mumbai, Government, Semi-Government, Central Government, Public Authority, National or Public Interest. The Agency shall make the Street Furniture item required as directed by the Authority for such display free of any advertisement on it. The Agency shall have no claim/compensation whatsoever against the Authority in this regard. The advertisement text/images would be given to the Agency for preparation of advertisement board. Composing the matter, preparation of creative, converting to any type and printing shall be responsibility of the agency. The agency shall carry out all the works stipulated in this item at his own cost at the location decided by the Authority.

13. **Compliance of Contract**

If the Agency shall neglect or fail to do anything which they have agreed to do under the terms and conditions of this contract, the OIC may serve a notice to the Agency asking it to do good the things agreed upon as aforesaid, and on their further neglect or failure to do so, the Authority shall have right to fine the Agency at its discretion or terminate the contract.

All the works as required to be done by the Agency under the different clauses of this contract shall be carried out by the Agency within the time specified and the manner set out and to the entire satisfaction of the said officers of the Authority. If the Agency fails to carry out the said works as aforesaid, the same shall be carried out by the Authority at its risk and cost and the Agency shall be liable and bound to pay the said charges for the same to the Authority immediately on demand at the following rates:

- i. If carried out by engaging any other agency then the cost of work carried out by the agency plus overhead charges at the rate of 10% of the total value of the work done through such agency.
- ii. If carried out by deploying departmental resources, the cost of work plus the overhead charges at the rate of 15% on the cost of labour and 20% on the cost of materials.

14. Agency's responsibility against all claims, actions, losses, etc.

- a. The Agency shall indemnify and keep indemnified MMRDA against all payment, claims, actions, demands, losses, costs, charges and expenses which the Authority may incur or be put to or which may arise by reason of the exercise of the right to erect and maintain the street furniture item or display advertisement on Authority's Street Furniture items hereby granted including claims or actions arising out of any advertisement being challenged or held to be libellous or defamatory or in consequence of the falling or displacement or breakage of any advertisement / component of Street Furniture items or otherwise, as the case may be, or part thereof, due to any reason whatsoever and also against any claim made by the local authority or any other person in respect thereof and against any claim for rates or taxes levied in respect of anything done under this contract. The Agency hereby undertake as an essential condition of this contract that they shall within 15 days of a notice in writing requiring them to do so, pay to MMRDA all moneys payable by them in respect of such claims, actions, demands, losses, costs, charges and expenses. On failure to do so the Authority shall be entitled to adjust/recover the money from the Security Deposit and the Agency shall make good the deficit so as to bring the security deposit to its original amount.
- b. If at any time during the continuance of this contract, it shall become impossible by reason of events like strike, lockout, war, fire, flood or any Government enactment or regulation or any order of the Hon'ble courts or any other cause beyond the control of the Authority, to fulfil the contract in respect of all or any site in accordance with the terms hereof, the Agency shall have no claim/damage/compensation, whatsoever against the Authority in respect of any inability or incapacity to fulfil the contract or non display of the advertisement.

However, the Agency may prematurely rescind the contract by giving (3) three months notice in writing of his intention to do so to the OIC, in case of event arising outlined in (b) above. The Agency shall have to pay the display charges during this period of notice. The said period of three months shall commence from the first day of the following month in which the notice of termination is given by the Agency. If the Agency makes the aforesaid payment without any demur or default, the Security Deposit would be returned to the Agency after expiry of six months from the date of termination of contract, subject to fulfilment of conditions stipulated in Clause No. 18(c). If however, the Agency makes any default in making the payment as aforesaid the OIC, shall forfeit the Security Deposit partly or fully as the circumstances of the case require.

15. Payment of Charges, Expenses, Municipal Licence Fees, etc.:

- a. The Agency shall be solely responsible for all payments including Municipal Licence Fees or any other charges levied by Municipal or other Public Authorities on account of displaying advertisement on Authority's Street Furniture Items at locations mentioned under this contract including any charges for erecting structure of Street Furniture item, etc. The Agency shall, within seven days from the date of intimation by the Authority, pay to the Authority or any concerned Authority rents, taxes, charges, Licence Fees, which are required to be paid by the Agency. The Street Furniture items shall be the property erected for benefiting public. The Authority shall in no way be responsible for the above payment. Any additional expenses or charges by way of penalty, interest/penal interest etc. in case of failure to pay shall be borne by the Agency.
- b. The Agency shall produce for verification of the OIC the original receipts in respect of the payment of Municipal Licence Fees and other rents and taxes levied by such Competent Authorities, whenever called upon to do so. The Agency shall produce the receipts in respect of the payment of Licence fees and other rents deposits etc. to the Authority every six months along with a photocopy for the Authority's record.
- c. If any such sum due remains unpaid by the Agency and the Authority is called upon by the concerned Authorities to make good the payment then the OIC, would be at liberty to make the payment from the security deposit of the Agency or any other amount from any other contract of the Agency available with the Authority/other Statutory Agency.

16. Payment of Display Charges & mode of payment

- a. The Agency shall pay to the Authority the display charges quoted by it in the 'Form of Financial Offer' by way of monthly instalment in advance by demand draft / pay order in favour of 'MMRD FUND' payable in Mumbai. The first instalment shall be paid on the last day of the construction period (i.e. 365th day) and the subsequent instalments shall be paid as advance on the same date of each month. The Total display charges divided by the days for which display will be done will yield display charges per day. Amount of annual instalment will be worked out by the multiplying the charges per day with no. of days in a year. And amount of annual instalment divided by the month in a year will yield the amount of monthly instalment payable by the agency. The amount of instalment will be worked out at above rates and communicated to be paid in advance.

- Instalment amount per day for Street Furniture items (M) =
$$\frac{\text{Total display charges mentioned in form of financial offer (K)}}{\text{Total display days as per actual agreement (5110)}}$$
- Instalment amount per year (N) = Instalment amount per day worked as above (M) X No. of days in year (365)
- Instalment amount per month (to be paid as advance at the beginning of the month) (Z) =
$$\frac{\text{Instalment amount per year worked as above (N)}}{\text{Months in a year (12)}}$$

Note: The display charges, No. of display days, amount of Instalments may vary as per actuals/work order. Based on the financial offer pro-rata display charges instalment will be calculated for completed work by the OIC and it will be binding on the bidder.

The Agency shall be required to pay to the Authority interest at 15% per annum on the balance amount for the period from the due date of payment as aforesaid, till the date, payment is actually received (both days inclusive) by the Authority. In case the payment is withheld beyond period of thirty days from the due date of payment, the Authority shall be at liberty to recover the due amount from security deposit or terminate the contract without any claim for compensation/refund by the Agency under provision of Clause No. 22. In case, the display days are reduced due to delay of

agency in completing of Street Furniture items' construction, MMRDA shall not be responsible for loss of revenue and instalment will not be reduced. But in case of reasons beyond control of Authority, the display could not commence, then the amount of instalment will be reduced proportioned to the days reduced or display days could be added as per the discretion of OIC.

- b. The Agency shall construct all the Street Furniture items and then apply for permission for display. If agency fails to construct Street Furniture items in the stipulated time, reasons shall be given and if they feel not satisfactory, the contract shall be terminated and no compensation will be paid to the agency and EMD and Security Deposit will be forfeited and the property constructed shall belongs to Authority.

c. Addition of Street Furniture Items

MMRDA reserves the right to increase the quantity of any of the street furniture items mentioned in Annexure 'A'. The agency shall not claim any compensation, if quantity of items in Annexure 'A' increases or decreases by 10% for each type. In case, the quantity increases beyond 10% Metropolitan Commissioner, MMRDA at its sole discretion may decide any form of compensation in terms of pro- rata display period/ pro- rata payment as may be deemed fit.

17. Insolvency of the Agency or non-observance of the obligation of contract on the part of Agency

If the Agency shall commit any act of insolvency or shall be adjudged insolvent or shall have an order for compulsory winding up made against them or pass an effective resolution for winding up voluntarily or subject to the supervision of the court or if the Agency shall suffer execution to be issued or shall suffer any payment under this contract to be attached or shall charge or encumber this contract or any payment due or which may become due to the Authority hereunder or compound with their creditors or if the Agency fail to observe and perform any of the obligations, covenants or agreements on their part herein contained or if the Agency shall go into liquidation, then on all or of such events happening, it shall be lawful for the OIC, to terminate this contract and take possession of Street Furniture Items & advertisements along with its frame work, if any, displayed under this contract and the same shall become the property of the Authority without prejudice to the rights of the OIC, to recover all

sums then due by way of rentals or consideration under this contract and damages, if any, in respect of any breach or default on the part of the Agency.

18. Payment of Security Deposit

- a. As security for the due fulfilment of the terms of this contract, the Agency shall deposit, with the Authority within **45 days** from the letter of acceptance (work order) from the Authority, an amount equal to 10% of the premium fee offered in 'Form of Financial Offer' (P.F) for whole concession period. The Agency shall deposit the amount of Security Deposit in the form of Bank Guarantee; which shall be required to be renewed every year before expiry. On failure of the Agency to submit the Security Deposit within the due date, penal interest @ 15% p.a. will be charged till the amount of Security Deposit is furnished by the Agency (both days inclusive). If the Agency further fails to deposit the amount of Security Deposit along with interest within Fifteen days after the expiry of due date, the contract awarded to the Agency shall stand terminated without issue of any further notice. However, the balance if any shall be paid as prescribed within time limit specified.
- b. In case the Agency is in arrears of any payments, the OIC shall give a notice of 15 days in writing to recover such amount. At the expiry of the notice, without any further consent on the part of the Agency, other than the consent which is implied by the execution of the agreement, to use/realise the said Security Deposit or any part thereof and to apply the proceeds of such realisation in or towards the payment and satisfaction of any and every sum which may be due by the Agency to the Authority or the Municipal Corporation of Mumbai, Mumbai Metropolitan Region Development Authority or any other Statutory Authority under this contract. If the Agency fails to honour any contractual obligation or defaults in making payment for any reason, then the Authority will be at liberty to recover the said cost from the Security Deposit or any other amount due and payable to the Agency. In such an event, the Agency shall make good the amount of Security Deposit to its original amount within Fifteen days of intimation by OIC to make good the amount, failing which the Authority would be at liberty to take such action as provided herein, including termination of contract.
- c. Refund of Security Deposit**
- i. The entire amount against Security Deposit shall be refunded only after complying with all the Conditions of the Bid under consideration, within 6 months after completion of concession period and after adjusting against

all incurred expenditure by MMRDA for doing good the damages made by agency.

- ii. The Agency shall also produce all the documentary evidence as may be required by the Authority so as to ensure that it has paid all dues to the MCGM and other Statutory Authorities for the individual site. (No Dues Certificate).

d. Forfeiture of Security Deposit

In the event the Agency commits a breach of any of the terms and conditions of the contract or fails to observe and comply with any of the requirements or arrears of any payment which is due for more than 30 days from issue of notice under this contract, the OIC, shall be entitled to forfeit the Security Deposit either in whole or in part thereof at his discretion without prejudice to other rights and remedies open to the Authority and it shall be binding on the Agency.

19. Non payment of charges

Any sum due and payable by the Agency to the Authority under this contract, if not paid within the prescribed time limit, shall be payable with 15% interest per annum (both days inclusive) irrespective of the fact whether the said condition is mentioned hereinabove or not.

20. Transfer of right

The Agency shall not assign, under-let, sub-let the contract or assign or transfer in any way the right granted under this contract to any person or persons or firm or Agency or Company without prior approval of the Authority. Also, the Agency shall not mortgage or rent-out any of the street furniture item during the concession period except Kiosks. Title of the land under any of the street furniture items shall not be transferable and at all the times shall be property of MMRDA.

21. Transfer of the Street Furniture items on the expiry / termination of the contract

Street Furniture items will be property of the Authority for the entire concession period and display of Advertisement will be prohibited after the expiry / termination of the contract.

The Agency shall remove all the advertisement boards on the Street Furniture items, if any displayed thereon, within 7 days from the last day of expiry /

termination of the contract. Also the agency shall handover all the street furniture items to Authority in good, workable conditions within 15 days from date of expiry/termination of contract. The agency shall make good all the defects within these 15 days before transfer to MMRDA.

On failure of the Agency to remove the advertisement within stipulated time, said advertisements shall be removed by the Authority at the risk and cost of the Agency and the agency shall be liable to pay the penalty of Rs. 5000/- per street furniture item/day to Authority till that item not get removed or as actual whichever is higher. On failure of agency to handover the street furniture items in good conditions, Authority shall make good the street furniture items at the cost and risk of Agency upto entire satisfaction of OIC. The required costs for both the events above shall be recovered from security deposit of the agency.

Due care shall be taken by the Agency while booking the contracts for advertisements on Street Furniture Items so that no advertisement is displayed after the expiry of this contract. These cost are based on 2012 prices and will be adjusted by the OIC on the actual year of levying during the concession period.

22. **Termination of Contract**

If, during the period of contract, the OIC has reasons to be dissatisfied with the execution of contract and/or the performance of the Agency, the OIC may by notice in writing call upon the Agency to remove the cause of such dissatisfaction in the way to be indicated in the notice and if the Agency fail for a period of 15 days after the receipt of such notice to remedy such cause of dissatisfaction to the satisfaction of the OIC then the OIC or the officer appointed by him shall serve a further 7 days notice to the Agency in writing and on failure of the Agency to follow the orders in the said notice and notwithstanding anything contained in the agreement to the contrary, the OIC shall have a right to terminate the contract by giving a final 7 days Notice in writing and the contract shall on expiry at the notice period stand terminated without prejudice to the right of the OIC to forfeit the Security Deposit as provided under clause 18(iv) of this contract. In addition to the Security Deposit the OIC shall have right to forfeit any other amount due and payable by the Agency under this or any other contract with the Authority. On termination of the contract the Agency shall also be liable to pay all sums including an amount equal to 25% of display charges for balance period payable to the Authority as on the date of termination of contract. This shall be in addition to the forfeiture

of 'Security Deposit' as provided under Clause no. 18 of the 'Conditions of Contract'. Also, the street furniture items shall be the property of Authority.

23. Jurisdiction of Court

The court located in Mumbai only shall have jurisdiction to try and decide the matter/dispute between the parties.

24. The Contract Agreement

The Agency whose bid has been accepted shall within one month from the date of acceptance letter (work order) enter into a written agreement with the Authority for the proper fulfilment of the contract on lines similar to the terms provided herein, failing which it shall be construed as if the Agency has entered into binding agreement with the Authority in terms of Clause No. 12 of the 'Instructions to Bidders'. The Agency shall also get the contract Agreement duly adjudicated upon from the stamp office at Mumbai.

In the event of the bid of a Partnership Firm/ company being accepted, the contract agreement shall be signed by all the partners of the Firm/ Company or by the competent persons on behalf of the Firm/ Company, subject to production of the necessary resolution or any other documents in support thereof. The form of draft Agreement is enclosed in Annexure 'C'.

25. Preparation of the Agreement

The Agreement shall be prepared and engrossed by the Authority and shall be forwarded to the Agency after the acceptance of its bid. Should the Agency not execute the Agreement after the date of its receipt by them as stated above, the Authority may, at its option and without prejudice to its other rights or claims against the Agency for non-compliance with any of the provisions of these conditions, within thirty days after the receipt of the Agreement by the Agency, by notice in writing to the Agency, revoke the acceptance of the bid and thereupon the Authority shall not be liable for any claim or demand from the Agency in respect of any matter or thing whatsoever in connection with the contract, but the Authority shall be entitled to the forfeiture of the Earnest Money deposited by the Agency alongwith the bid or the Security Deposit paid by the Agency on the intimation of acceptance of this bid.

26. Stamp Duty

The stamp duty shall be borne by the Agency and an amount of Rs.100/- being the cost of preparation of the Agreement in duplicate shall be paid by the Agency within seven days from the date of acceptance letter.

27. The Agency shall comply with the provision of ESI Act, 1948, amended from time to time and shall pay the contribution (employees and employers) in respect of labourers employed by Agency such contribution shall be paid through the Authority's ESI Department. It shall be obligatory on the part of the Agency to pay, if any liability arises at the time of ESI Inspection.

- a. It shall be obligatory on part of the Agency to submit the declaration forms Nos. 1 and 3 in accordance with regulation 11 read with regulation 14 of the above mentioned Act within 3 days from the date of commencement of the work to the ESI Section/Dept. of the Authority duly certified by the Head of the Department. No payment shall be released to the Agency till the compliance of said formalities.
- b. The Agency shall also submit Attendance and Wage Register of all labourers engaged on work (employees covered under ESI or beyond ESI) every month on or before 10th day of the next month for on going works to the Authority's ESI Section/Dept. duly certified by the Department concerned and representative of Audit Department. The amount to be paid towards ESI contribution will be intimated to the Agency by the ESI Section/Dept. within 3 working days from the date of submission of Attendance/Wage Register.

For those works which are to be completed in short duration i.e. one month or less than one month, the Agency shall submit Attendance and Wage Register, immediately on completion of work and payment of Wages to the labourers, duly certified by the Department concerned and representative of Audit Department. The Agency will also comply with the requirement as stated in para (ii) above.

- c. In the event of failure of comply with the above requirement, the Agency shall be liable to pay penalty comprising of penal interest presently at 12% p.a. as per Regulation 31A and damages as per Regulation 31C depending upon the period of delay in payment of usual ESI contribution and the same will be paid to ESI Contribution under separate challan. No dispute on this account will be entertained. The decision of OIC in this regard shall be final.
- d. In case the ESI covered employees of the Agency continue working and drawing wages within insurable wage ceiling beyond 30th September and 31st March, the information in respect of these employees such as name of the employee, his insurance number and the name and code number of the ESI

Panel Doctor with whom he has registered his name shall be furnished to the ESI Section on 10th Day of the following months.

28. The Agency shall make its own arrangement for Drinking Water/other water and Electricity required for the project. The water and/or sewerage charges wherever applicable shall be paid to the appropriate Authority directly at its cost and should submit receipts thereof to the Authority.

29. **Removal of Debris**

The Agency shall remove the debris from the site of work within 24 Hrs. from the date of written instructions to the Agency to that effect, failing which the Authority will remove the same by engaging any other agency or departmentally and the cost of the same shall be recovered as stipulated in the Condition No. 13 of the 'Conditions of Contract' from any money due to them, such decision shall not form the subject matter of any dispute.

30. **Safety Measures**

The work shall be carried out without causing any inconvenience to the pedestrians, shop owners, etc., in the vicinity. The Agency shall further take all necessary precautions such as display boards, signals, barricading of sites, posting of watchmen etc., before starting the work and all expenses on this account shall be borne by the Agency. The Agency shall not cut / prune the branches of the tree in the vicinity of the Street Furniture Items without prior written permission of the Supdt. of Garden Department / Tree Authority of the MCGM. The necessary permission shall be obtained by the Agency at its cost.

31. All reinstatement work shall be done by the Agency so as to match with the surrounding surfaces at their own cost, to the satisfaction of the OIC.
32. The Agency's attention is drawn to the Contract Labour (Regulation and Abolition) Act, 1970 and the Maharashtra Contract Labour (Regulation and Abolition) Rules, 1971. The Agency shall comply with the provisions of the said Act and Rules framed there under.
33. Before submitting the bid, the Bidder if so desired may inspect the sites of Street Furniture Items and then quote his offer accordingly. The location can slightly vary depending upon the site conditions and the location before erection shall be got marked from OIC by the Agency.
34. If any damage is caused to the surrounding property while carrying out the work by the Agency, the same shall be made good free of cost.

35. Illegal Gratification

Any bribe, commission, gift or advantage given, promised or offered by or on behalf of the Agency, agent or servant of any one on their behalf of any officer, or employee of the Authority or to any person on their behalf in relation to the obtaining or the execution of this or any other Contract with the Authority shall, in addition to any criminal liability which they may incur, subject the Agency to the recession of the contract and all other contracts with the Authority and to the payment of any loss or damage resulting from such recession, and the Authority shall be entitled to deduct the amount so payable from any monies due to the Agency under the contract or any other contract with the Authority. The Agency shall not lend or borrow from or have to enter into any monetary dealings or transactions either directly or indirectly with any employee of the Authority and if they shall do so the Authority shall be entitled forthwith to rescind the contract and all other contracts with the Authority. The OIC shall settle any question of dispute as or to the commission of any offence or compensation payable to the Authority under this clause in such a manner as he shall consider fit and sufficient and his decision shall be final and conclusive.

36. Termination of contract for death

If the Agency is an individual or a proprietary concern and the individual or the Proprietor dies and if the Agency is a partnership concern and one of partners die then unless the OIC is satisfied that the legal representative of the individual or the proprietor of the proprietary concern and in the case of partnership, the surviving partners, are capable of carrying out and completing the contract, the OIC shall be entitled to cancel the contract as to its incomplete part without the Authority being in any way liable for payment of any compensations to the estate of the Agency and/or to the surviving partners of the Agency on account of the cancellation of the contract. The decision of the OIC, that the legal representative of the Agency or the surviving partners of the Agency cannot carry out and complete the contract shall be final and binding on the parties. In the event of such cancellation the Authority shall have discretion to hold / not hold the estate of the Agency and/or the surviving partners of the Agency liable in damages for not completing the contract.

37. The OIC may from time to time delegate his powers to any officer of the Authority for execution of contract and all the decisions, orders issued by the said officer shall be binding on the Agency. If any doubt, dispute or difference arises or happens between the Officer on the one hand and the Agency on the

- other hand in respect of the said works or any of them or relating to the quantities, qualities, workmanship, description or manner of work done and executed by the Agency or to be quantity or quality of the materials to be employed therein or in respect of any additions, deductions, alterations or deviations made into or from the said works or any part thereof or of any plans, drawings, conditions, recoveries or of any instructions, orders, directions referred to therein or which may be furnished or given during the progress of the works or in respect of any certificate of payment, order which have been made or in any way whatsoever relating to the interest of the Authority or of the Agency in the premises, every such doubt dispute and difference shall within 14 days of the occurrence of the doubt, dispute, difference be referred to the Metropolitan Commissioner, MMRDA who shall give his decision within a period of 90 days. The decision of the Metropolitan Commissioner, MMRDA shall be final and binding on the Agency.
38. Subject as otherwise provided in this contract all notices to be given on behalf of Authority and all other actions to be taken on its behalf may be given or taken by the OIC. All notices, communications, references and complaints made by the Authority or the Officer's representative or the Agency inter-se concerning the work shall be in writing and no notice communication, reference or complaint not in writing shall be recognised, and if sent by registered post and under certificate of posting to the last known place or abode or business of the Agency shall be deemed to have been served on the date when in the ordinary course of post these would have been served on or delivered to him.
39. Notice from the Agency to the Authority shall be served to the OIC personally or by registered post addressed to the Authority at their office address of Mumbai Metropolitan Region Development Authority (MMRDA), Bandra-Kurla Complex, Bandra (East), Mumbai-400 051.
- 40 .i. The Agency shall comply with the Policy Guidelines of Grant of Permission for display of Sky signs and advertisement under section 328 and 328A of MMC Act 1888.
- 40 .ii. The Agency shall also comply with section 116(4) of Motor Vehicles Act 1988 while displaying advertisement.
41. **Rounding off amounts**
- The total amount due towards Display Charges shall be rounded off to the nearest rupee. An amount of 50 paise and below shall be ignored and 51 paise and above shall be reckoned as one rupee.

42. Penal Action

- a. If the Bidder after submitting the BID withdraws or varies it within the validity period the Bidder shall be liable to be banned for bid participation future from the Authority for a period of **Five years** that shall be reckoned from the date of withdrawing or varying the bid.
- b. The Agency after award of contract shall perform the contract with due diligence of the 'Conditions of Contract' put to bid, failing which it shall be construed upon as the Agency has defaulted in honouring contractual obligations and the defaulting Agency **after termination of contract** shall thus be liable for penal action so as to debar the defaulting Agency from having **dealing with the Authority** either permanently or for the period as shall be decided by the Authority.

The penal action shall be without prejudice to the rights and remedies available to the Authority and also be in addition to the action to be instituted against the defaulting Agency under other terms and conditions of the contract.

43. Precaution during monsoon: The Agency shall ensure that no water stagnation takes place near the Street Furniture items and shall carry out such measures as directed by OIC from time to time at his cost. The site shall not create any damage to pedestrian/traffic flow etc. Any accidents/claims out of it etc. shall be the responsibility of the agency.

44. Conflict of interest

The BKC area of E, G and Gn blocks for which the bids have been invited will have street furniture items as detailed in this bid. Erection of any advertisements or hoardings or any street furniture items in the same area by other agency shall directly conflict with the sustainability of the successful bidder. Therefore, this shall not be allowed. However, if in emergency, MMRDA decides to erect the same; it shall not be considered as conflict of interest.

If MMRDA decides to erect any other street furniture item(s) mentioned in Annexure A with or without advt. in BKC, the right of first refusal shall be given to successful bidder of this bid to avoid any conflicts/litigation and payment of premium, display period, etc. shall be decided by Metropolitan Commissioner, MMRDA..

45. Early termination of contract by Agency

In case, the agency terminates/withdraw/cancels the contract on his will before expiry of concession period, the street furniture items shall be the property of

MMRDA and no rights, howsoever, shall be established by the agency and security deposit shall be forfeited by MMRDA.

46. Insurance

Insurance during the Construction Period: The agency shall, at its cost and expense, purchase and maintain during the Construction Period such insurances as are necessary, including but not limited to the following:

- i. builders' all risk insurance;
- ii. workmen's compensation insurance;
- iii. third party insurances;

any other insurance that may be necessary to protect the agency, its employees and its assets (against loss, damage or destruction, at replacement value) including all Force Majeure Events that are insurable and not otherwise covered in items (i) to (iii).

Insurance during the Operations Period: The agency shall, at its cost and expense, purchase and maintain during the Operations Period insurance to cover against:

- i. loss, damage or destruction of the Project Facility, at replacement value;
- ii. the agency's general liability arising out of the Concession;
- iii. liability to third parties; and

any other insurance that may be necessary to protect the agency and its employees, including all Force Majeure Events that are insurable and not otherwise covered in items (i) to (iii).

The agency shall, from time to time, provide to MMRDA copies of all Insurance Policies (or appropriate endorsements, certifications or other satisfactory evidence of insurance) obtained by the agency in accordance with this bid.

47. MMRDA reserves the right to amend any of the conditions in contract in larger public interest and the same shall be binding on the agency without any cost to MMRDA.
48. For any discrepancy in the bid, the decision of Metropolitan Commissioner, MMRDA shall be final and binding on the bidders.

CHAPTER – 4
FORM OF FINANCIAL OFFER

To,

The Joint Project Director,
Town Planning,
Development Authority (MMRDA),
Bandra-Kurla Complex,
Bandra (East), Mumbai 400 051.

I/We hereby offer to pay premium fees/display charges filled below for erection and maintenance of Street Furniture items and display of advertisements at various locations in 'E', 'G', and 'GN' blocks of Bandra-Kurla Complex as furnished in the Annexure 'A', 'D' & 'E' on such terms and conditions as described in the accompanying 'Instructions to Bidders', 'Form of Bid' and 'Conditions of Contract'.

I/We hereby offer to the Authority the Lump sum display charges as stipulated below:

We shall pay these amounts as per terms and conditions of this Contract bid.

For Advt. Area of 2066 Sq.M.	Display Charges for 5110 days – (K)	
	Rs. in Figures	Rs. in Words
Erection of Street Furniture in BKC on DBMOT basis as per BID		

[Display period= (15 years X 365 days) – 365 days of construction period]

Signature of Bidder : _____

Name of Bidder : _____

Correspondence address: _____

Tel No. & Fax No. : _____

Mob No. : _____

E-mail : _____

ANNEXURE – A**Statement of Street Furniture for (E, G and GN Block)**

Sr. No	Street Furniture	Quantity (No)		TOTAL QTY.	Advertisement / Non-advertisement
		E BLOCK	G & G N BLOCK		
1	Bench	50	169	219	No
2	Litter Bin	50	178	228	No
3	Information Board	6	18	24	Yes
4	Direction Board	20	182	202	No
5	Multipurpose Booth	5	17	22	Yes
6	Flag Pole	NIL	50	50	Yes
7	Vending Kiosk	2	08	10	Yes
8	Public Convenience	2	07	09	Yes
9	Bollard	100	1000	1100	No
10	Pole Mounted CIP	10	41	51	Yes
11	Bus Queue Shelter	01	29	30	Yes
12	Tree Guard	50	1000	1050	No
13	Bicycle Stand	2	7	09	Yes
14	Bicycles	50	250	300	No

(Locations and specifications of the Street Furniture items mentioned above shall be as indicated in Annexure 'D' and 'E')

ANNEXURE – B

DEFINITIONS AND INTERPRETATION

In this bid, the following words and expressions shall, unless repugnant to the context or meaning thereof, have the meaning hereinafter respectively assigned to them.

“Accounting Year” means the financial year commencing from 1st April of any calendar year and ending on 31st March of the next calendar year;

“Additional Facilities” means the facilities which the Concessionaire may provide or procure for the benefit of the users of the Street furniture and which are in addition to the Project Facilities, and not situated on the Site;

“Applicable Laws” means all laws, promulgated or brought into force and effect by GOI or GOM including regulations and rules made thereunder, and judgments, decrees, injunctions, writs and orders of any court of record, as record, as may be in force and effect during the subsistence of this Agreement;

“Applicable Permits” means all clearances, permits, authorizations, consents and approvals required to be abstained or maintained under Applicable Laws in connection with the design, engineering, financing, procurement, construction, operation and maintenance of the Street Furniture Project during the subsistence of this Contract;

“Appointed Date” means the date on which this Concession Agreement is executed and shall be deemed to be the date of commencement of the Concession Period;

“Arbitration Act” means in relation to either Party and/ or Consortium Members, a person who controls, is controlled by, or is under the common control with such Party or Consortium Member. As used in this definition, the expression “control” means with respect to a person which is a corporation, the ownership, directly or indirectly, of more than 50% of the voting shares of such person, and with respect to a person which is not a corporation, the power to direct the management and policies of such person, whether by operation of law or by contract or otherwise;

“Authority” means Mumbai Metropolitan Region Development Authority (MMRDA);

“Change in Law” means the occurrence of any of the following after the date of Financial Bid:

1. the enactment of any new Indian law;
2. the repeal, modification or re-enactment of any existing Indian law;

3. the commencement of any Indian Law which has not entered into effect until the date of financial Bid;
4. a change in the interpretation or application of any Indian law by a court of record as compared to such interpretation or application prior to the date of financial Bid;

“Agency” means the Agency acting as the Concessionaire under this Agreement;

“Company” means a Company incorporated and existing under Companies Act, 1956

“Completion Certificate” means the Certificate issued by the OIC

“Concession” means the concession set forth herein; including the exclusive right, license and authority to erect, operate and maintain the project for a period specified herein; granted by the Authority to the concessionaire against the concessionaire’s services and obligations.

“Concession Period” means 5475 days, the period beginning from the Appointed Date.

“Construction Period” Means the period of 365 days from the date of appointed date or as mentioned in the work order whichever is less unless otherwise extended by MMRDA.

“Construction Works” means all works and things necessary to complete the Street Furniture Project in accordance with this contract;

“Contractor” means the person or persons if any with whom the Concessionaire has entered into all or any of the Project Agreements other than the Financing Documents;

“DBOMT” means to Design, Build, Operate, Maintain and Transfer the street furniture items under this contract;

“Development” means all works and things necessary to complete the Street Furniture Project for use of the pedestrians and other users thereof in accordance with this Agreement;

“Document” or “Documentation” means documentation printed or in written form, tapes, discs, drawings, computer programmers, writings, reports, photographs, cassettes, or expressed in any other written, audio or visual form;

“Drawings” means all the drawings, calculations and documents pertaining to the Street Furniture Project and shall include “as built” drawings of the Street Furniture items as approved by the owner’s Consultants/Independent Engineer;

“Local Authority” Means Municipal Corporation of Greater Mumbai (MCGM);

“MMRDA Representative” means such person or persons as may be authorized in writing. MMRDA to act on its behalf under this Agreement and shall include any person or Persons having authority to exercise any rights or perform and fulfill any obligations of MMRDA under this Agreement;

Unless excluded by or repugnant to the context.

- a. The expression “OIC” as used anywhere in the document shall mean Officer working as Joint Project Director (Town Planning) of MMRDA.
- b. The expression “Officer” or “Officer-in-charge” (OIC) as used in the document shall mean the officer who is Joint Project Director (Town Planning) or any other person appointed by him for the project.
- c. The expression “Contract” as used in the document shall mean the deed to contract together with its original accompaniment and those latter incorporated in it by mutual consent.
- d. “Drawings” shall mean the drawings referred to in the specifications and any modifications of such drawings approved in writing by OIC and such other drawings as may from time to time be furnished or approved in writing by the Officer.
- e. “Officer’s representative” shall mean an Assistant of the Officer-in-charge.
- f. The “site” shall mean the lands and/or other places, on under, in or through which the work is to be executed under the contract including any other lands or places which may be allotted by MMRDA or used for the purpose of execution of work.
- g. The “Work” shall mean the works to be executed in accordance with the Contract or part(s) thereof as the case may be and shall include all extra or additional, altered or substituted works as required for performance of the Contract.
- h. The “Contract sum” shall mean the sum for which the offer is accepted.
- i. The “Accepting Authority” shall mean the Competent Authority to accept the bid.
- j. The “Day” shall mean a Calendar day of 24 hours from midnight to midnight irrespective of the number of hours worked in any day in that week.
- k. “Temporary works” shall mean all temporary works of every kind required in or about the execution, completion, or maintenance of the works.
- l. “Urgent works “ shall mean any measure which, in the opinion of the Officer-in-charge, become necessary during the progress of the works to obviate any risk or accident or failure or which become necessary for security of the work or the persons working, thereon.

ANNEXURE – C**FORM OF DRAFT CONTRACT AGREEMENT**

This CONTRACT (hereinafter called the “Contract”) is made on the ____ of the _____ of 2013 between, on the one hand, MUMBAI METROPOLITAN REGION DEVELOPMENT AUTHORITY (MMRDA) established and constituted under the Metropolitan Region Development Authority Act, 1974 (Maharashtra Act IV of 1975) and having its office at Plot No. C-14 and 15, Bandra-Kurla Complex, Bandra (East), Mumbai- 400 051 hereinafter called the “Authority” (which expression shall, unless it be repugnant to the context or meaning thereof, be deemed to include its successor or successors and assignee or assignees) and on the other hand M/s. _____ having its registered office at _____ hereinafter called the “Concessionaire” (which expression shall, unless it be repugnant to the context or meaning thereof, be deemed to include its successor or successors and assignee or assignees)

WHEREAS:

- a. The Authority has selected the Bidder to erect and maintain Street Furniture items in Bandra-Kurla Complex on Design-Build-Operate-Maintain-Transfer basis as per the specifications mentioned in the Bid Document (no. JPD/SF/2013) and as defined in the General Conditions of Contract.
- b. By filling the bid document and signing it the Bidder has agreed to the Authority that they have the required professional skills, personnel, technical and financial resources and have agreed execute the items in the bid document on the terms and conditions set forth in this Contractual bid document.

NOW THEREFORE the parties hereto hereby agree as follows:

The following documents attached hereto shall be deemed to form an integral part of this Contract Agreement.

- a. The complete bid document including the Common Set of Deviation issued from time to time.
- b. Minutes of the pre-bid meeting standard set of deviations/ corrigendum, drawing and instructions issued by OIC etc.

c. Any other communications issued prior to signing of the Agreement.

IN WITNESS WHEREOF, the parties hereto have caused this Contract to be signed in their respective names as of the day and year first above written.

FOR AND ON BEHALF OF
MUMBAI METROPOLITAN REGION
DEVELOPMENT AUTHORITY

By S.C. Deshpande
Joint Project Director (Town Planning),
MMRDA
(Authorised Representative)

Witness:

1. _____
2. _____

SCAN DOCUMENT

FOR AND ON BEHALF OF

M/s. _____

By _____
(Authorized Signatory)

Witness:

1. _____
2. _____

ANNEXURE – D
SPECIFICATIONS

A. Specifications:

Sr. No.	Street Furniture Item- SF	Quantity of SF in E ,G and G-N BLOCKS	Overall Size (mm)	Advt area per SF in sqmt	Total Advt Area in sqmt	Detail dwg and specifications
1	Bench	219	1.5 -1.8 m long	--	nil	Appendix - I
2	Litter bins	228	350mm dia. , 600 mm height	--	nil	Appendix - II
3	Information Boards	24	3.0 m X 2.2 m	12	288	Appendix - III
4	Direction Board	202	Site specific	--	Nil	Appendix - IV
5	Multipurpose Booth	22	Internal dia. 1.67 m 4.3 m height	15	330	Appendix - V
6	Flag pole	50	1.16 m x 1.71 m	4	200	Appendix - VI
7	Vending Kiosk	10	3.6m (L) X 2.5m (H) X 1.5m (W)	15	150	Appendix - VII
8	Public Convenience	09	4.2m (L) X 2.6m (H) X 2.3m (W)	15	135	Appendix - VIII
9	Bollards	1100	75 – 100 mm dia. , 600-900 mm (H)	--	nil	Appendix -IX
10	Pole Mounted CIP	51	1.3 m X 1.8 m, 2.2 m (H) above GL	5	255	Appendix - X
11	Bus Queue Shelters	30	2.6 m (H) x 2.7 m (W) x 6.0 m (L)	20	600	Appendix - XI
12	Tree Guard	1050	1.5 m dia.	--	nil	Appendix -XII
13	Bicycle stand	9	1 module for 20 cycles	12	108	Appendix -XIII
14	Bicycle	300	In 3 years	-	-	-
TOTAL ADVT AREA					2066	SQMT

[In case of addition of any of the quantity, clause 16 (c) of 'Conditions of Contract' shall apply]

General Conditions:

1. The above mentioned Street Furniture items and their respective specifications are minimum. Agency may propose better specifications than specified above. They shall form the integral part of this project, at sole discretion of OIC. All the materials used for the street furniture items shall be non flammable and suitable for all weather conditions.
2. The agency shall follow all the bye laws, guidelines, norms and standards as set out by any Statutory Authority with regards to the erection of Street Furniture items and advertising thereon. Also, prior permission of the same shall also be taken by the agency at its cost and risk and payment of License fees, taxes, or any other sum payable to such authorities shall be sole responsibility of the agency.
3. The agency shall alone be responsible for lost/theft/damage, etc. of any of the street furniture items.
4. The agency shall be responsible for the electric, water supply and other required connections required for any of the Street Furniture item. Also, he shall be responsible for disposing-off the litter, drainage, etc. at the locations approved by the OIC. Further to this, the agency shall be responsible to pay all the bills, charges, etc. of any services used for any street furniture items.
5. No bill boards or hoardings shall be a part of this project.
6. All the Street Furniture items shall be fixed to the ground with concrete foundation, etc. so that they cannot be removed easily.
7. The Agency, may, as per the design, proposed by him, display the advertisement of any product/company on the Street Furniture item; not exceeding the overall advt. area as specified above. While submitting the drawings for approval to the OIC, the Agency shall clearly mark the proposed space for advertising. Along with the approval from the OIC, the Agency shall also take prior approval from other Concerned Authorities as may be required. All the street furniture items shall have MMRDA's logo of proportionate size as approved by OIC.

ANNEXURE – E

LOCATIONAL DRAWINGS

The location drawings indicating tentative locations of street furniture are available in Autocad on MMRDA website for free download.

SCAN DOCUMENT

CHECK LIST

Envelope	Contents	To be Super scribed as	Page no in Bid document
Envelope 'A'	1. Earnest Money in form of Demand Draft payable in Mumbai for amount of Rs. 50.00 Lakhs	'Envelope A'	3
	2. Documents to support the Eligibility as per item 16 of the 'Instructions to Bidders'.		4
	3. Technical proposal [as per item 23 (i) of 'Instructions to Bidders']		7
Envelope 'B'	Financial offer [as per item 23 (ii) of 'Instructions to Bidders']	'Envelope B'	9
Envelope 'C'	Sealed envelope A and sealed envelope B to be put in Envelope C	'Bid for Erection of Street Furniture on DBMOT Basis in Bandra-Kurla Complex in Mumbai'	

SPECIFICATIONS BENCH

a	Functional	<ul style="list-style-type: none"> The bench shall be 1.5-1.8 m length It has to accommodate three persons comfortably It shall be placed on footpath to allow pedestrians to pass-by without disturbing the user Seat back with FRP/Synthetic wood with temperature resistant material which makes comfortable for the user during day/monsoon proof anti rust proof . Bolted to ground – vandalism proof
b	Maintainability	<ul style="list-style-type: none"> The furniture shall be totally maintenance free Regular cleaning and surface polishing shall be done to maintain the furniture as in new condition all the times. The surface shall not be rough and hard and users shall feel comfortable while sitting all the time .
c	Vandalism-proof	<ul style="list-style-type: none"> Furniture Parts shall be structurally safe , strong and safely secured to its foundation with minimum 10 mm anchor fasteners or chemical fasteners which will make the furniture more vandal proof .The material used shall be of non inflammable material.
d	Security & Safety considerations	<ul style="list-style-type: none"> All edges shall be completely soft and safe for users and shall avoid any harm from any injury likely to happen due to sharp edges and fastened to each other using anti theft screws as mentioned earlier.
e	Durability	<ul style="list-style-type: none"> Material used shall be cast iron with hot galvanization. Synthetic wood/FRP is water resistant and the design does not allow water to keep stagnant on the surface. Synthetic wood/FRP shall not be easily cracked and produce splinters. The Foundation slab shall be made in min M25 concrete. The cast iron , nuts bolts , shall be rust proof , deep galvanized , powder coated etc . The stainless steel shall be treated to be resistant in all weathers.
f	Aesthetics	<ul style="list-style-type: none"> Looks shall be elegant and smooth curves which makes it aesthetically good and appealing for the pedestrian to use it It shall be innovative and gel with the modern looks of the area and shall be state of the art .
g	Co-ordinated design of the various items	<ul style="list-style-type: none"> All the furniture is of the same color family
h	Modularity	<ul style="list-style-type: none"> The street furniture shall be modular
i	Environment considerations	<ul style="list-style-type: none"> All materials shall be recyclable .
j	Disable Friendliness	<ul style="list-style-type: none"> This furniture shall be very disabled friendly . Design and manufacture should comply with ISO-9001 requirements.
k	Innovativeness	<ul style="list-style-type: none"> The design shall be state of the art and befitting the built form of BKC. The design shall be original and creative.

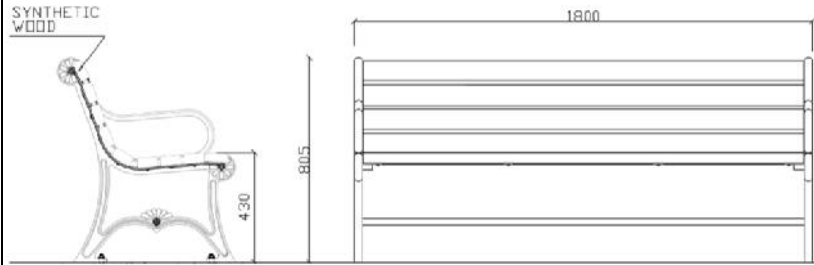

ALTERNATIVE -1

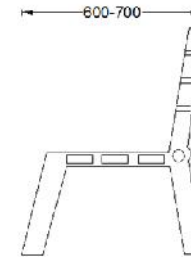
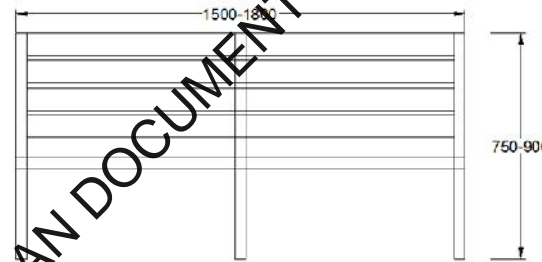

ALTERNATIVE -2

SCAN DOCUMENT

	<p>MUMBAI METROPOLITAN REGION DEVELOPMENT AUTHORITY</p>
	<p>TECHNICAL SPECIFICATIONS AND DETAILS OF STREET FURNITURE (SF) – BENCH</p>
<p>Appendix- I</p>	<p>Drawings not to scale. All dimensions in mm . Strictly follow written dimensions only</p>
<p>NOTE: The Alternatives are indicative and for reference purpose only and shall act as minimum set benchmark. The bidders shall submit better design in the BID and the SF SPECS proposed by the bidder shall fulfill minimum SPECS mentioned in the adjoining Table. The above SF designs are patented to the companies and are erected in New Delhi and the bidders are prohibited to use these in this BID unless they possess valid copyright and patent certification from the parent company. MMRDA shall stand indemnified to this effect.</p>	

SPECIFICATIONS

LITTER BIN

a	Functional	<ul style="list-style-type: none"> The standing structure shall take a minimum footprint on ground. The basket shall be with minimum capacity of 60 liters. The whole bin body shall be with opens around hinges to access the basket. Bins shall be incorporated with Pole Mounted Panels to minimise the furniture's foot print wherever possible.
b	Maintainability	<ul style="list-style-type: none"> The galvanized steel bins and structure shall be coated with polyester powder coating The bins shall be made such a way for easy to maintain. .
c	Vandalism-proof	<ul style="list-style-type: none"> The opening of basket for cleaning shall be secured by a lock which needs an anti vandalism key to be operated. The supporting structure shall be safely secured to its foundation with minimum 12mm anchor fasteners or chemical fasteners which makes the furniture stable..
d	Security & Safety Considerations	<ul style="list-style-type: none"> All surfaces shall be smooth without sharp angles All materials shall be non flammable
e	Durability	<ul style="list-style-type: none"> Hot galvanization process shall be used for steel guarantees a long rust free life. The Foundation slab shall be made in min M25 concrete. The cast iron , nuts bolts , shall be rust proof , deep galvanized , powder coated etc . The stainless steel shall be treated to be resistant in all weathers
f	Aesthetics	<ul style="list-style-type: none"> Looks shall be simple and well designed to go with the existing look of the city Shape shall be consistent between free standing litter bin and pole mounted litter bin. If used to minimize the furniture foot print.
g	Co-ordinated design of the various items	<ul style="list-style-type: none"> All the furniture shall be of the same color family
h	Modularity	<ul style="list-style-type: none"> Bin body and basket shall be used on free standing unit or pole unit.
i	Environment considerations	<ul style="list-style-type: none"> All materials shall be recyclable
j	Disable Friendliness	<ul style="list-style-type: none"> The height of aperture of bin shall be easily accessible for wheeled chair persons Design and manufacture should comply with ISO-9001 requirements
k	Innovativeness	<ul style="list-style-type: none"> The design shall be state of the art and befitting the built form of BKC. The design shall be original and creative.

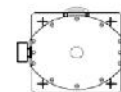
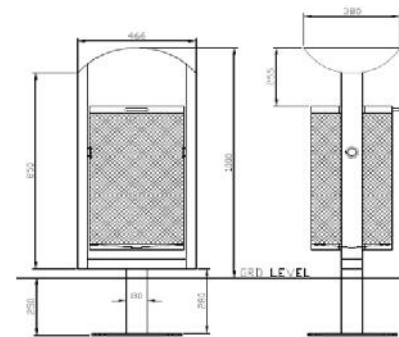

ALTERNATIVE -1

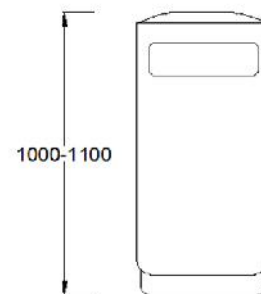
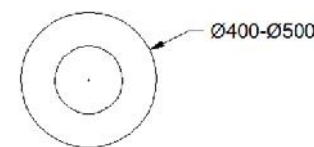

ALTERNATIVE -2

SCAN DOCUMENT

	MUMBAI METROPOLITAN REGION DEVELOPMENT AUTHORITY
	TECHNICAL SPECIFICATIONS AND DETAILS OF STREET FURNITURE (SF) – LITTER BIN
Appendix- II	Drawings not to scale. All dimensions in mm . Strictly follow written dimensions only
<p>NOTE: The Alternatives are indicative and for reference purpose only and shall act as minimum set benchmark. The bidders shall submit better design in the BID and the SF SPECS proposed by the bidder shall fulfill minimum SPECS mentioned in the adjoining Table. The above SF designs are patented to the companies and are erected in New Delhi and the bidders are prohibited to use these in this BID unless they possess valid copyright and patent certification from the parent company. MMRDA shall stand indemnified to this effect.</p>	

SPECIFICATIONS INFORMATION BOARD

a	Functional	<ul style="list-style-type: none"> The Information Panel shall be a light box on a cantilever structure with a single pole or a support structure with two poles having display area of dimension 3070 mm x2220 mm on two sides. It shall allow pedestrians to pass under it without any restrain for height. The Furniture shall be composed of a panel assembled on a metallic pole. The display systems shall ensure that the posters are rightly tensioned for a good display quality. The display systems can have fixed or scrolling faces. The scrolling posters shall be driven by plastic belts in order to minimise the noise The structure shall be safe to withstand wind pressure as per the regulations.
b	Maintainability	<ul style="list-style-type: none"> The furniture shall be maintained using soap water with pressured pump for washing and periodic service. The display shall be covered with unbreakable glass or such transparent material and shall be cleaned periodically. The poles and metal parts shall be coated for rust protection.
c	Vandalism-proof	<ul style="list-style-type: none"> Furniture parts shall be structurally safe, strong, and safely secured to its foundation with min. 20 mm anchor fasteners or chemical fasteners which make the furniture more stable and joint fasteners not visible from outside. Joints shall be fastened using anti-theft mechanism which can be operated only by specially designed keys.
d	Security	<ul style="list-style-type: none"> All surfaces shall be smooth without sharp angles All materials shall be non flammable
e	Durability	<ul style="list-style-type: none"> The parts used shall be of steel, aluminum and tempered glass for better durability. All the steel parts shall be HDG –Hot dip galvanized and Aluminum parts shall be anodized or powder coated to give longer life and better quality. The Foundation slab shall be made in min M25 concrete. The cast iron nuts bolts, shall be rust proof, deep galvanized, powder coated etc. The stainless steel shall be treated to be resistant in all weathers. The glass shall be assembled with gaskets properly. The furniture shall be made from materials unaffected by outdoor exposure.
f	Aesthetics	<ul style="list-style-type: none"> Looks shall be elegant and smooth curves which makes it aesthetically good and appealing for the pedestrian to use it It shall be innovative and gel with the modern looks of the area and shall be state of the art.
g	Co-ordinated design of the various items	<ul style="list-style-type: none"> All information board shall be of uniform shape, size, colour on the same width of the road. However for smaller road width the dimension shall get proportionally reduced.
h	Modularity	<ul style="list-style-type: none"> The design shall be uniform and scalable.
i	Environment considerations	<ul style="list-style-type: none"> All materials shall be recyclable.
J	Disable Friendliness	<ul style="list-style-type: none"> This furniture shall be very disabled friendly. Design and manufacture should comply with ISO-9001 requirements.
K	Innovativeness	<ul style="list-style-type: none"> The design shall be state of the art and befitting the built form of BKC. The design shall be original and creative.

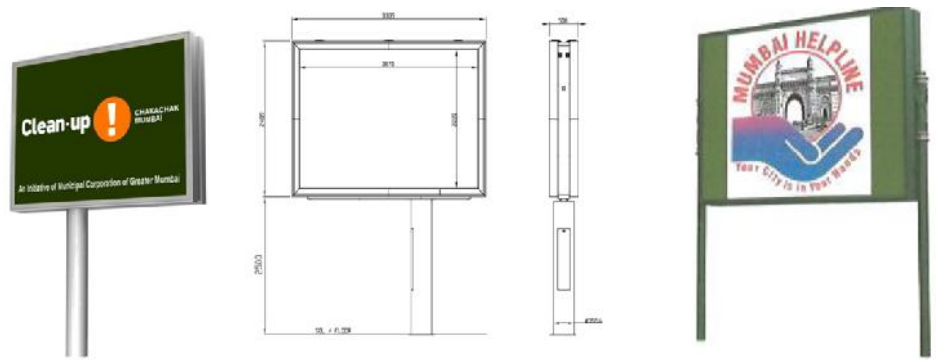

ALTERNATIVE -1

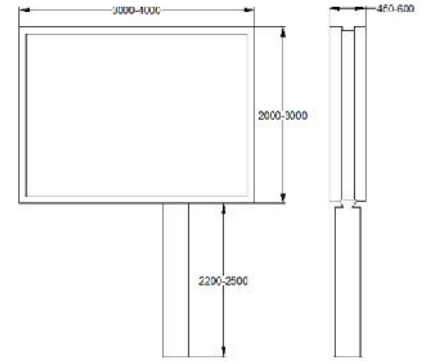

ALTERNATIVE -2

	MUMBAI METROPOLITAN REGION DEVELOPMENT AUTHORITY
	TECHNICAL SPECIFICATIONS AND DETAILS OF STREET FURNITURE (SF) – INFORMATION BOARD
Appendix- III	Drawings not to scale. All dimensions in mm. Strictly follow written dimensions only
<p>NOTE: The Alternatives are indicative and for reference purpose only and shall act as minimum set benchmark. The bidders shall submit better design in the BID and the SF SPECS proposed by the bidder shall fulfill minimum SPECS mentioned in the adjoining Table. The above SF designs are patented to the companies and are erected in New Delhi and the bidders are prohibited to use these in this BID unless they possess valid copyright and patent certification from the parent company. MMRDA shall stand indemnified to this effect.</p>	

SPECIFICATIONS DIRECTION BOARD

a	Functional	<ul style="list-style-type: none"> The Signage shall be used to identify the route and landmarks shall be Visible on man height during day and night with retroreflexity. The structure shall be safe to withstand wind pressure as per the regulations.
b	Maintainability	<ul style="list-style-type: none"> The galvanized structure shall be coated with polyester powder coating The signage shall be easy to maintain by regular cleaning Instruction plate shall be replaceable in case of scratched or destroyed.
c	Vandalism-proof	<ul style="list-style-type: none"> Direction board parts shall be structurally safe, strong, and safely secured to its foundation with min. 20 mm anchor fasteners or chemical fasteners which make the furniture more stable and joint fasteners not visible from outside. Joints shall be fastened using anti-theft mechanism which can be operated only by specially designed keys.
d	Security & Safety considerations	<ul style="list-style-type: none"> All surfaces shall be smooth without sharp angles All materials shall be non flammable
e	Durability	<ul style="list-style-type: none"> The parts used shall be of steel, aluminum for better durability. All the steel parts shall be HDG –Hot dip galvanized and Aluminum parts shall be anodized or powder coated to give longer life and better quality. The Foundation slab shall be made in min M25 concrete. The cast iron , nuts bolts , shall be rust proof , deep galvanized , powder coated etc . The stainless steel shall be treated to be resistant in all weathers. The furniture shall be made from materials unaffected by outdoor exposure.
f	Aesthetics	<ul style="list-style-type: none"> Looks shall be elegant and smooth curves which makes it aesthetically good and appealing for the pedestrian to use it It shall be innovative and gel with the modern looks of the area and shall be state of the art.
g	Co-ordinated design of the various items	<ul style="list-style-type: none"> All information board shall be of uniform shape, size, colour on the same width of the road. However for smaller road width the dimension shall get proportionally reduced.
h	Modularity	<ul style="list-style-type: none"> The design shall be uniform and scalable.
i	Environment considerations	<ul style="list-style-type: none"> All materials shall be recyclable .
j	Disable Friendliness	<ul style="list-style-type: none"> This furniture shall be disabled friendly . Design and manufacture should comply with ISO-9001 requirements.
k	Innovativeness	<ul style="list-style-type: none"> The design shall be compliant with IRC 67-2010 Standards and all relevant circulars and government orders.

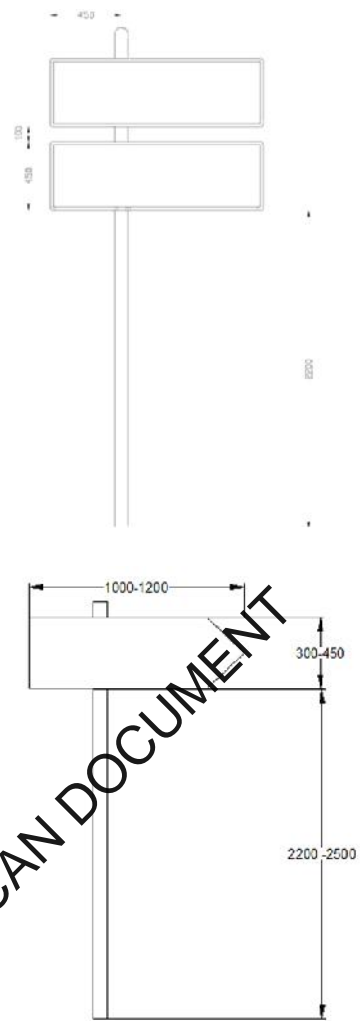

ALTERNATIVE -1



ALTERNATIVE -2

	MUMBAI METROPOLITAN REGION DEVELOPMENT AUTHORITY
	TECHNICAL SPECIFICATIONS AND DETAILS OF STREET FURNITURE (SF) – DIRECTION BOARD
Appendix- IV	Drawings not to scale. All dimensions in mm . Strictly follow written dimensions only
<p>NOTE: The Alternatives are indicative and for reference purpose only and shall act as minimum set benchmark. The bidders shall submit better design in the BID and the SF SPECS proposed by the bidder shall fulfill minimum SPECS mentioned in the adjoining Table. The above SF designs are patented to the companies and are erected in New Delhi and the bidders are prohibited to use these in this BID unless they possess valid copyright and patent certification from the parent company. MMRDA shall stand indemnified to this effect.</p>	

SPECIFICATIONS MULTIPURPOSE BOOTH

a	Functional	<ul style="list-style-type: none"> The multipurpose booth can be used as police booth/water fountain or security guard cabin etc. The booth shall be 4640 mm high and 200 mm in dia. This will accommodate one police man/guard comfortably. The structure shall be cylindrical and canopy shall give protection from rain and sun. The booth shall have electrical and water points with drinking water purifier, and top hung door with about 8 sqm face to allow easy entry and exit and shall be secured with unique key. The water fountain booth shall be provided with water storage tank and UV water purifier. <p>MMRDA shall have exclusive rights to use this Multipurpose Booth.</p>
b	Maintainability	<ul style="list-style-type: none"> The furniture shall be maintenance free and shall be periodic cleaned and polished. The furniture shall be re-coated with the appropriate color whenever necessary. The furniture shall be made up of aluminum, steel, cast iron and polycarbonate to avoid maintenance
c	Vandalism-proof	<ul style="list-style-type: none"> The parts used shall not be fragile and shall be safely secured to its foundation with 14 or 16 mm anchor fasteners or chemical fasteners to make the furniture more stable and joint fasteners shall not be visible from outside. The glazing shall be of polycarbonate material to offer good resistance against shocks and scratches with no visible fixings.
d	Security & Safety considerations	<ul style="list-style-type: none"> All edges shall be completely soft and safe without sharp corners. The doors shall open with specific safety key only.
e	Durability	<ul style="list-style-type: none"> Materials used shall be cast iron, steel and aluminum with anti corrosion treatment. The design is water resistant and water proof thanks to rubbered gaskets. The Foundation slab shall be made in m 25 concrete. The cast iron , nuts bolts , shall be rust proof , deep galvanized , powder coated etc . The stainless steel shall be treated to be resistant in all weathers. The material used shall be unaffected by outdoor exposure The material shall be Non flammable.
f	Aesthetics	<ul style="list-style-type: none"> The furniture shall be with smooth curves and elegant look. The advertising display shall make the booth more friendly to pedestrians at night time with their bright lighting, beautiful brand creative and information .
g	Co-ordinated design	<ul style="list-style-type: none"> All booths shall be of uniform shape, size, colour on the same width of the road.
h	Modularity	<ul style="list-style-type: none"> The design shall be uniform and scalable.
i	Environment considerations	<ul style="list-style-type: none"> All materials shall be recyclable
j	Disable Friendliness	<ul style="list-style-type: none"> This furniture shall be disabled friendly . Design and manufacture should comply with ISO-9001 requirements.
k	Innovativeness	<ul style="list-style-type: none"> The design shall be state of the art and befitting the built form of BKC. The design shall be original and creative.

POLICE BOOTH



ALTERNATIVE -1

ALTERNATIVE -2



WATER FOUNTAIN/MULTIPURPOSE BOOTH

	MUMBAI METROPOLITAN REGION DEVELOPMENT AUTHORITY
	TECHNICAL SPECIFICATIONS AND DETAILS OF STREET FURNITURE (SF) – MULTIPURPOSE BOOTH
Appendix- V	Drawings not to scale. All dimensions in mm . Strictly follow written dimensions only
<p>NOTE: The Alternatives are indicative and for reference purpose only and shall act as minimum set benchmark. The bidders shall submit better design in the BID and the SF SPECS proposed by the bidder shall fulfill minimum SPECS mentioned in the adjoining Table. The above SF designs are patented to the companies and are erected in New Delhi and the bidders are prohibited to use these in this BID unless they possess valid copyright and patent certification from the parent company. MMRDA shall stand indemnified to this effect.</p>	

SPECIFICATIONS FLAG POLE

a	Functional	<ul style="list-style-type: none"> It shall have a display equipment with information area showing 1160mmx1710mm double sided and unique with flag mounted at top. It shall be made of Aluminum frame work, 8mm toughened glass and electronic circuit to control its lighting, 2 glazed doors hinged on top of panel and kept in open position with gas struts. The display systems can have fixed or scrolling faces. The scrolling posters shall be driven by plastic belts in order to minimise the noise The structure shall be safe to withstand wind pressure as per the regulations. <p>The contents of Flag shall not violate any sentiments/Acts/Rules etc.</p>
	Maintainability	<ul style="list-style-type: none"> The furniture shall be maintained using soap water with pressured pump for washing and periodic servicing of the doors and parts inside the furniture. The display shall be covered using an 8 mm toughened glass with protective frames on its edges, to be cleaned periodically. The poles and metal parts shall be coated for protection in case found damaged.
c	Vandalism-proof	<ul style="list-style-type: none"> The parts used shall not be fragile and it shall be safely secured to its foundation with 14 or 16 mm anchor fasteners or chemical fasteners which makes the furniture more stable and joint fasteners not visible from outside. None of the joints will be visible from outside the furniture and it is completely sealed. Open able only by specialized key.
d	Security & Safety considerations	<ul style="list-style-type: none"> The parts used shall not be fragile and shall be safely secured to its foundation with 14 or 16 mm anchor fasteners or chemical fasteners to make the furniture more stable and joint fasteners shall not be visible from outside. The glazing shall be of polycarbonate material to offer good resistance against shocks and scratches with no visible fixings. The display shall not over hang on the road, to cause any accident by passing vehicles.
e	Durability	<ul style="list-style-type: none"> The parts used shall be of steel, aluminum for better durability. All the steel parts shall be HDG –Hot dip galvanized and Aluminum parts shall be anodized or powder coated to give longer life and better quality. The Foundation slab shall be made in min M25 concrete. The cast iron, nuts bolts, shall be rust proof, deep galvanized, powder coated etc. The stainless steel shall be treated to be resistant in all weathers The material used shall be unaffected by outdoor exposure The material shall be Non flammable.
f	Aesthetics	<ul style="list-style-type: none"> The looks shall be simple and well designed to gel with the existing look of BKC. The frame of the display shall be coated with shades to make the display like a photo frame.
g	Co-ordinated design of the various items	<ul style="list-style-type: none"> All information board shall be of uniform shape, size, colour on the same width of the road. The location of the flag poles shall be near the public buildings, convention centers, exhibition grounds, etc
h	Modularity	<ul style="list-style-type: none"> The flag pole shall be easily dismantle. No national flag shall be hosted. MMRDA shall stand indemnified for any issues due to hosting of flag.
i	Environment considerations	<ul style="list-style-type: none"> All materials except the fiber glass can be recyclable.
j	Disable Friendliness	<ul style="list-style-type: none"> This furniture shall be disabled friendly. Design and manufacture should comply with ISO-9001 requirements.
k	Innovativeness	<ul style="list-style-type: none"> The design shall be state of the art and befitting the built form of BKC. The design shall be original and creative.

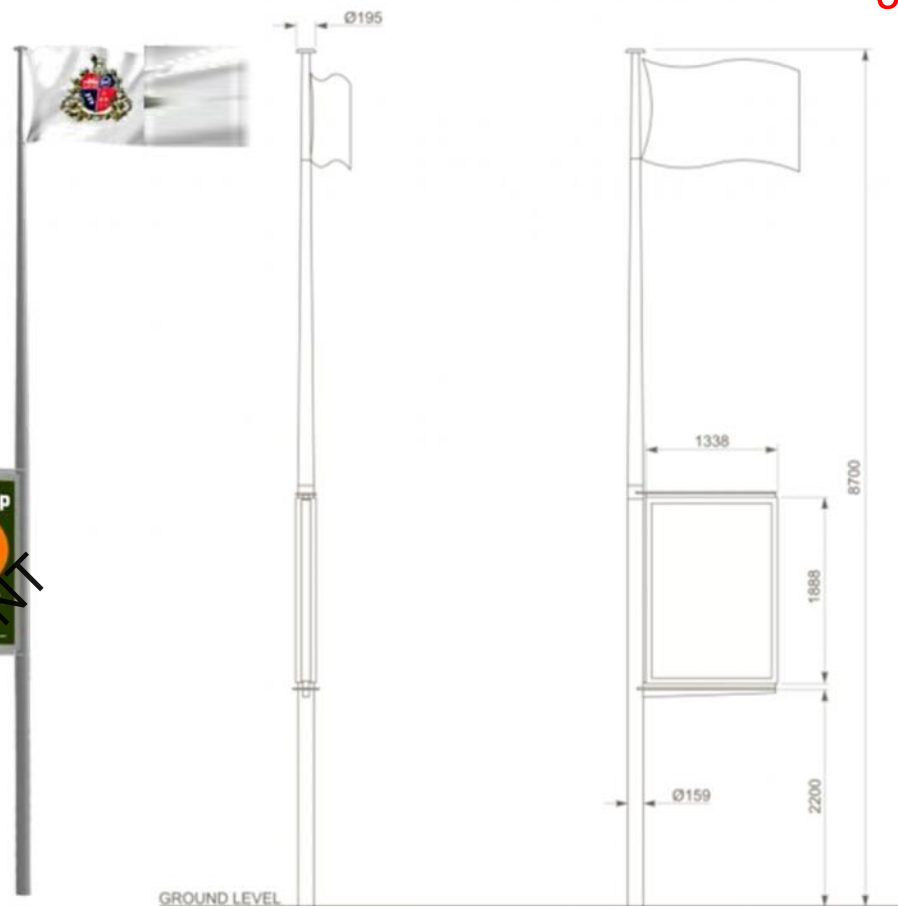
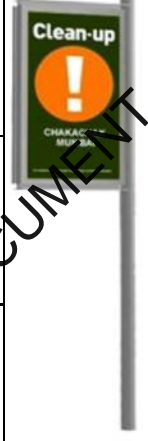

FLAG POLE

	MUMBAI METROPOLITAN REGION DEVELOPMENT AUTHORITY
	TECHNICAL SPECIFICATIONS AND DETAILS OF STREET FURNITURE (SF) – FLAG POLE
Appendix- VI	Drawings not to scale. All dimensions in mm. Strictly follow written dimensions only

NOTE: The Alternatives are indicative and for reference purpose only and shall act as minimum set benchmark. The bidders shall submit better design in the BID and the SF SPECS proposed by the bidder shall fulfill minimum SPECS mentioned in the adjoining Table. The above SF designs are patented to the companies and are erected in New Delhi and the bidders are prohibited to use these in this BID unless they possess valid copyright and patent certification from the parent company. MMRDA shall stand indemnified to this effect.

SPECIFICATIONS VENDING KIOSK

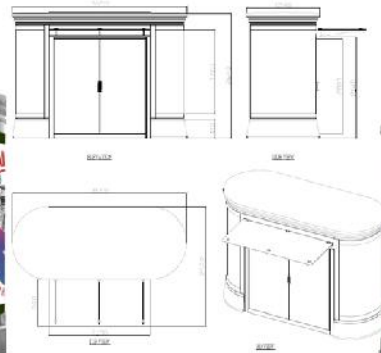

Back view

Front view

ALTERNATIVE -1

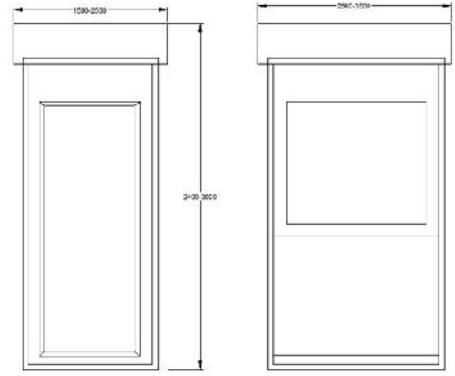

ALTERNATIVE -2

SCAN DOCUMENT

a	Functional	<ul style="list-style-type: none"> The display racks shall be fitted to the inside walls and to the inner side of the door. The 3 flux mounted backlit advertising panels shall be on the sides and on the rear. The two doors shall be situated on front face equipped with backlit panel and display racks. The display systems shall ensure that the posters are rightly tensioned for a good display quality. The electrical cabinet in vending kiosk shall be inaccessible to the public. The backlit of the different panels and backlit of the doors display racks shall illuminate goods for sale. The kiosk shall have natural ventilation and extendable canopy to protect from sunlight and rain. The height of the kiosk between ground and canopy shall be atleast 2200mm, to allow free passage of users. <p style="text-align: center;">The usage/users of Kiosk shall have to be got approved from MMRDA.</p>
b	Maintainability	<ul style="list-style-type: none"> The furniture shall need little maintenance but periodic cleaning and surface polishing shall be done to maintain the furniture. The kiosk shall be made of aluminum, steel, and tempered glass, requiring little maintenance.
c	Vandalism-proof	<ul style="list-style-type: none"> The parts used shall not be fragile and shall be safely secured to its foundation with 12 mm anchor fasteners or chemical fasteners to make the furniture more stable and joint fasteners shall not be visible from outside. The access doors and cash drawer and locking of display panels shall be with specific safety key.
d	Security & Safety considerations	<ul style="list-style-type: none"> All edges shall be completely soft and safe without sharp corners. The doors, display doors, front doors, shall open with specific safety key only.
e	Durability	<ul style="list-style-type: none"> The materials used shall be steel/aluminum with anti corrosion treatment. The design shall be water resistant and water proof thanks to rubber gaskets. The material used shall be unaffected by outdoor exposure The material shall be Non flammable.
f	Aesthetics	<ul style="list-style-type: none"> Smooth curves and look are elegant, which makes it aesthetically good and appealing. The advertising displays makes the kiosk more friendly to pedestrians at night time with their bright lighting, beautiful brand creative and information .
g	Co-ordinated design of the various items	<ul style="list-style-type: none"> All vending kiosk shall be of uniform shape, size, colour on the same width of the road. The location of the kiosk shall be near the public buildings, convention centers, exhibition grounds, etc
h	Modularity	<ul style="list-style-type: none"> The design shall be uniform and scalable.
i	Environment considerations	<ul style="list-style-type: none"> All materials shall be recyclable
j	Disable Friendliness	<ul style="list-style-type: none"> This kiosk shall be accessible on wheel chair and the display shall be at comfortable height.
k	Innovativeness	<ul style="list-style-type: none"> The design shall be state of the art and befitting the built form of BKC. The design shall be original and creative.

	MUMBAI METROPOLITAN REGION DEVELOPMENT AUTHORITY
	TECHNICAL SPECIFICATIONS AND DETAILS OF STREET FURNITURE (SF) – VENDING DESK
Appendix- VII	Drawings not to scale. All dimensions in mm . Strictly follow written dimensions only
<p>NOTE: The Alternatives are indicative and for reference purpose only and shall act as minimum set benchmark. The bidders shall submit better design in the BID and the SF SPECS proposed by the bidder shall fulfill minimum SPECS mentioned in the adjoining Table. The above SF designs are patented to the companies and are erected in New Delhi and the bidders are prohibited to use these in this BID unless they possess valid copyright and patent certification from the parent company. MMRDA shall stand indemnified to this effect.</p>	

SPECIFICATIONS PUBLIC CONVENIENCE

a	Functional	<ul style="list-style-type: none"> The toilet shall be symmetrical piece of furniture with separate facilities for Male and Female. The whole unit shall be hoisted and moved. Entrance doors shall be opposite to the road side and shall be 900mm wide. Each toilet room shall be equipped with a toilet seat with manual flushing system, WC tap, toilet paper dispenser, wall handle bar, sink with running water and soap dispenser, mirror, exhaust fan, and ceiling light. Whole toilet shall be put on clean concrete slab foundation at 0-400 mm level depending on site condition and shall be removable. The display systems shall ensure that the posters are rightly tensioned for a good display quality. <p style="text-align: center;">This shall be accessible to entire public free of cost .</p>
b	Maintainability	<ul style="list-style-type: none"> All inner accessories in contact with user shall be made up of stainless steel. Toilet bowl shall be of porcelain. Toilet seat shall be of polyethylene Inner walls shall be clad with aluminum composite panels which shall be easy to clean. Ground shall be covered with tiles The furniture shall be maintained using soap water with pressured pump for washing and periodic servicing of the doors, walls, ground and parts inside the furniture Ground shall have a small slope towards an evacuation hole. Accessibility shall be given to electricity, water and sewage connections
c	Vandalism-proof	<ul style="list-style-type: none"> All lighting parts shall be protected with metal mesh which prohibits direct contact with users. There shall be no access to water tank for users.
d	Security & Safety considerations	<ul style="list-style-type: none"> Doors shall be equipped with inner locks. However, a specific key shall allow opening from outside in case of emergency. The water tank shall be fed a water tap from public network. Toilet, sink and evacuation hole shall have own siphon to the sewerage
e	Durability	<ul style="list-style-type: none"> The parts used shall be of galvanized steel, aluminum, with polyester powder coating or polyurethane lacquer and accessories shall be made of stainless steel. The material used shall be unaffected by outdoor exposure The material shall be Non flammable.
f	Aesthetics	<ul style="list-style-type: none"> Look shall be simple and well designed to gel with the existing look of the city The frame of the displays shall be coated with shades making the displays like a photo frame
g	Co-ordinated design of the various items	<ul style="list-style-type: none"> All public convenience shall be of uniform shape, size, colour on the same width of the road. The location of the kiosk shall be near the public buildings, convention centers, exhibition grounds, etc
h	Modularity	<ul style="list-style-type: none"> The design shall be uniform and scalable.
i	Environment considerations	<ul style="list-style-type: none"> All materials shall be recyclable
j	Disable Friendliness	<ul style="list-style-type: none"> Wall handle bar shall be designed to help disabled people to get access to the toilet seat. The access shall be possible with wheel chair. A ramp shall allows the chair to roll inside.
k	Innovativeness	<ul style="list-style-type: none"> The design shall be state of the art and befitting the built form of BKC. The design shall be original and creative.



ALTERNATIVE -1

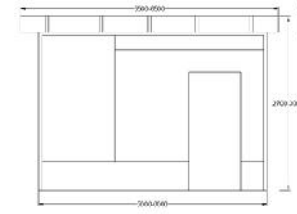

ALTERNATIVE -2

	MUMBAI METROPOLITAN REGION DEVELOPMENT AUTHORITY
	TECHNICAL SPECIFICATIONS AND DETAILS OF STREET FURNITURE (SF) – PUBLIC CONVENIENCE
Appendix- VIII	Drawings not to scale. All dimensions in mm . Strictly follow written dimensions only
<p>NOTE: The Alternatives are indicative and for reference purpose only and shall act as minimum set benchmark. The bidders shall submit better design in the BID and the SF SPECS proposed by the bidder shall fulfill minimum SPECS mentioned in the adjoining Table. The above SF designs are patented to the companies and are erected in New Delhi and the bidders are prohibited to use these in this BID unless they possess valid copyright and patent certification from the parent company. MMRDA shall stand indemnified to this effect.</p>	

SPECIFICATIONS

BOLLARD

a	Functional	<ul style="list-style-type: none"> The bollards of concrete/cast iron / steel etc shall serve the purpose of defining the edge of the road and guide pedestrians at junctions to the zebra crossing and shall discipline the flow of pedestrians towards the junctions with crossings and shall be provided at all junctions.
b	Maintainability	<ul style="list-style-type: none"> The furniture shall be maintained using soap water with pressured pump for washing. The poles and metal parts shall be coated for protection in case found damaged.
c	Vandalism-proof	<ul style="list-style-type: none"> The bollards shall not be fragile and safely secured to its foundation
d	Security & Safety considerations	<ul style="list-style-type: none"> The foundation used shall be designed in order to take loads from pedestrians and parked cars and other factors There are no sharp edges visible or reachable by citizens,
e	Durability	<ul style="list-style-type: none"> The parts used shall be of steel for better durability. All the steel parts shall be HDG – Hot dip galvanized powder coated to give longer life and better quality. The Foundation slab shall be made in min M25 concrete. The cast iron , nuts bolts , shall be rust proof , deep galvanized , powder coated etc . The stainless steel shall be treated to be resistant in all weathers.
f	Aesthetics	<ul style="list-style-type: none"> Look shall be simple and well designed to gel with the existing look of the city
g	Co-ordinated design of the various items	<ul style="list-style-type: none"> All bollards shall be of uniform shape, size, color on the same width of the road. The location of the bollards shall be near the public buildings, convention centers, exhibition grounds, junctions etc where pedestrian movement is predominant.
h	Modularity	<ul style="list-style-type: none"> The design shall be uniform and scalable.
i	Environment considerations	<ul style="list-style-type: none"> All materials shall be recyclable
j	Disable Friendliness	<ul style="list-style-type: none"> The bollards spacing shall allow the wheel chair access.
k	Innovativeness	<ul style="list-style-type: none"> The design shall be state of the art and befitting the built form of BKC. The design shall be original and creative.

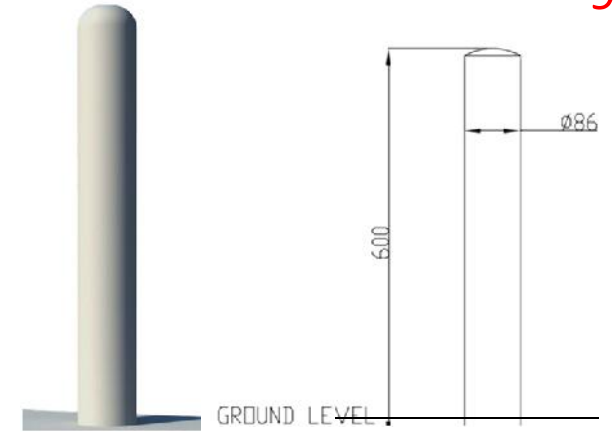

9

ALTERNATIVE -1



ALTERNATIVE -2



	MUMBAI METROPOLITAN REGION DEVELOPMENT AUTHORITY
	TECHNICAL SPECIFICATIONS AND DETAILS OF STREET FURNITURE (SF) – BOLLARD
Appendix- IX	Drawings not to scale. All dimensions in mm . Strictly follow written dimensions only

NOTE: The Alternatives are indicative and for reference purpose only and shall act as minimum set benchmark. The bidders shall submit better design in the BID and the SF SPECS proposed by the bidder shall fulfill minimum SPECS mentioned in the adjoining Table. The above SF designs are patented to the companies and are erected in New Delhi and the bidders are prohibited to use these in this BID unless they possess valid copyright and patent certification from the parent company. MMRDA shall stand indemnified to this effect.

SPECIFICATIONS POLE MOUNTED CIP

a	Functional	<ul style="list-style-type: none"> City information panel –CIP shall be a display equipment with information area showing 1160mmx1710mm double sided. It shall be made of Aluminum frame work, 8mm toughened glass and electronic circuit to control its lighting. It shall have 2 glazed doors are hinged on top of panel and kept in open position with gas struts. The structure shall be designed to withstand wind load according to regulations. The display systems can have fixed or scrolling faces. The scrolling posters shall be driven by plastic belts in order to minimise the noise
b	Maintainability	<ul style="list-style-type: none"> The furniture shall be maintained using soap water with pressured pump for washing and periodic servicing of the doors and parts inside the furniture. The display shall be covered using an 8 mm toughened glass with protective frames on its edges ,which shall be also cleaned periodically. The poles and metal parts shall be coated for protection in case found damaged.
c	Vandalism-proof	<ul style="list-style-type: none"> The Parts used shall not be fragile and safely secured to its foundation with 14 or 16 mm anchor fasteners or chemical fasteners which makes the furniture more stable and joint fasteners not visible from outside. None of the joints shall be visible from outside the furniture and it is completely sealed. Opening shall be by specialized key.
d	Security & Safety considerations	<ul style="list-style-type: none"> There shall be no falling parts involved in the furniture all the parts shall be well fastened. The foundation used shall be designed in order to take loads from wind and persons leaning over the panel. There shall be no sharp edges visible or reachable by passers. The display shall not overhang on the road to avoid any accident of passing vehicle.
e	Durability	<ul style="list-style-type: none"> The parts used shall be of steel , aluminum and toughened glass for better durability. The Foundation slab shall be made in min M25 concrete. The cast iron , nuts bolts , shall be rust proof , deep galvanized , powder coated etc . The stainless steel shall be treated to be resistant in all weathers. The material used shall be unaffected by outdoor exposure The material shall be Non flammable.
f	Aesthetics	<ul style="list-style-type: none"> Looks shall be simple and well designed to go with the existing look of the city. The frame of the display shall be coated with shades making the display like a photo frame .
g	Co-ordinated design of the various items	<ul style="list-style-type: none"> All pole mounted CIP shall be of uniform shape, size, colour on the same width of the road. The location of the CIP shall be near the public buildings, convention centers, exhibition grounds, etc
h	Modularity	<ul style="list-style-type: none"> The flag pole shall be easily dismantle.
i	Environment considerations	<ul style="list-style-type: none"> All materials except the fiber glass can be recyclable .
j	Disable Friendliness	<ul style="list-style-type: none"> This furniture shall be very disabled friendly . Design and manufacture should comply with ISO-9001 requirements.
k	Innovativeness	<ul style="list-style-type: none"> The design shall be state of the art and befitting the built form of BKC. The design shall be original and creative.

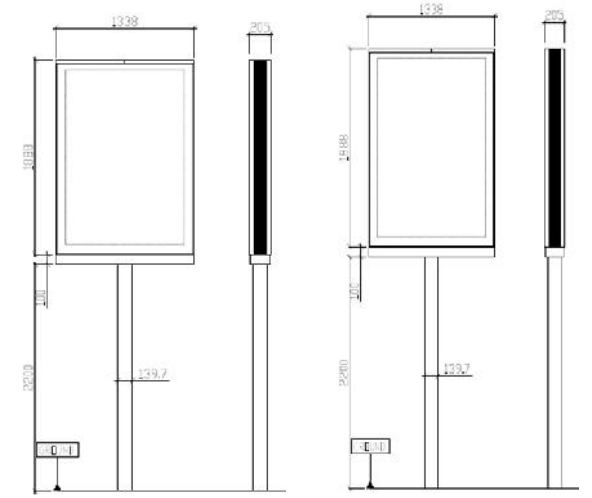

ALTERNATIVE -1

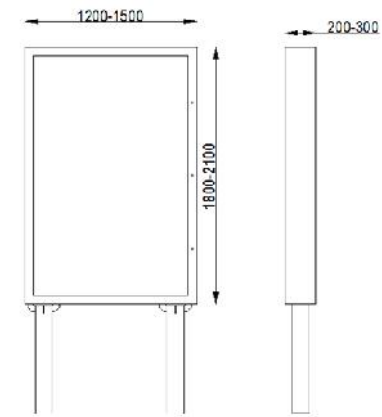

ALTERNATIVE -2

	MUMBAI METROPOLITAN REGION DEVELOPMENT AUTHORITY
	TECHNICAL SPECIFICATIONS AND DETAILS OF STREET FURNITURE (SF) – POLE MOUNTED CIP
Appendix- X	Drawings not to scale. All dimensions in mm . Strictly follow written dimensions only
<p>NOTE: The Alternatives are indicative and for reference purpose only and shall act as minimum set benchmark. The bidders shall submit better design in the BID and the SF SPECS proposed by the bidder shall fulfill minimum SPECS mentioned in the adjoining Table. The above SF designs are patented to the companies and are erected in New Delhi and the bidders are prohibited to use these in this BID unless they possess valid copyright and patent certification from the parent company. MMRDA shall stand indemnified to this effect.</p>	

SPECIFICATIONS

BUS Q SHELTER

a	Functional	<ul style="list-style-type: none"> Bus Q Shelter – BQS shall serve as a all weather shade for the bus commuters and the display area per bqs shall not exceed 20 sqmt.. It shall be made of Aluminum frame work, 8mm toughened glass and electronic circuit to control its lighting. The structure shall be designed to withstand wind load according to regulations. The display systems can have fixed or scrolling faces. The scrolling posters shall be driven by plastic belts in order to minimise the noise
b	Maintainability	<ul style="list-style-type: none"> The furniture shall be maintained using soap water with pressured pump for washing and periodic servicing of the doors and parts inside the furniture. The display shall be covered using an 8 mm toughened glass with protective frames on its edges ,which shall be also cleaned periodically. The poles and metal parts shall be coated for protection in case found damaged.
c	Vandalism-proof	<ul style="list-style-type: none"> The Parts used shall not be fragile and safely secured to its foundation with 14 or 16 mm anchor fasteners or chemical fasteners which makes the furniture more stable and joint fasteners not visible from outside. None of the joints shall be visible from outside the furniture and it is completely sealed. Opening shall be by specialized key.
d	Security & Safety considerations	<ul style="list-style-type: none"> There shall be no falling parts involved in the furniture all the parts shall be well fastened. The foundation used shall be designed in order to take loads from wind and persons leaning over the panel. There shall be no sharp edges visible or reachable by passers. The display shall not overhang on the road to avoid any accident by passing vehicle.
e	Durability	<ul style="list-style-type: none"> The parts used shall be of steel , aluminum and toughened glass for better durability. All the steel parts shall be HDG –Hot dip galvanized and aluminum parts shall be anodized or powder coated to give longer life and better quality. The material used shall be unaffected by outdoor exposure The material shall be Non flammable. The Foundation slab shall be made in min M25 concrete. The cast iron , nuts bolts , shall be rust proof , deep galvanized , powder coated etc . The stainless steel shall be treated to be resistant in all weathers.
f	Aesthetics	<ul style="list-style-type: none"> Looks shall be simple and well designed to go with the existing look of the city. The frame of the display shall be coated with shades making the display like a photo frame .
g	Co-ordinated design of the various items	<ul style="list-style-type: none"> All BQS shall be of uniform shape, size, colour on the same width of the road. The location of the BQS shall be governed by BEST and as indicated in the BID .
h	Modularity	<ul style="list-style-type: none"> The BQS shall be modular and similar or better than the existing provided as indicated in the photo .
i	Environment considerations	<ul style="list-style-type: none"> All materials except the fiber glass can be recyclable .
j	Disable Friendliness	<ul style="list-style-type: none"> This furniture shall be very disabled friendly . Design and manufacture should comply with ISO-9001 requirements.
k	Innovativeness	<ul style="list-style-type: none"> The design shall be state of the art and befitting the built form of BKC. The design shall be original and creative.

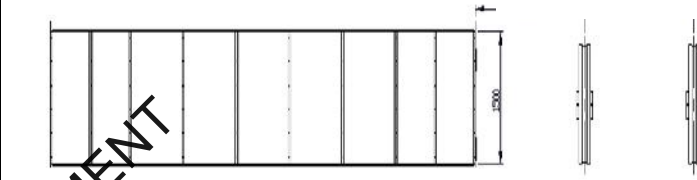
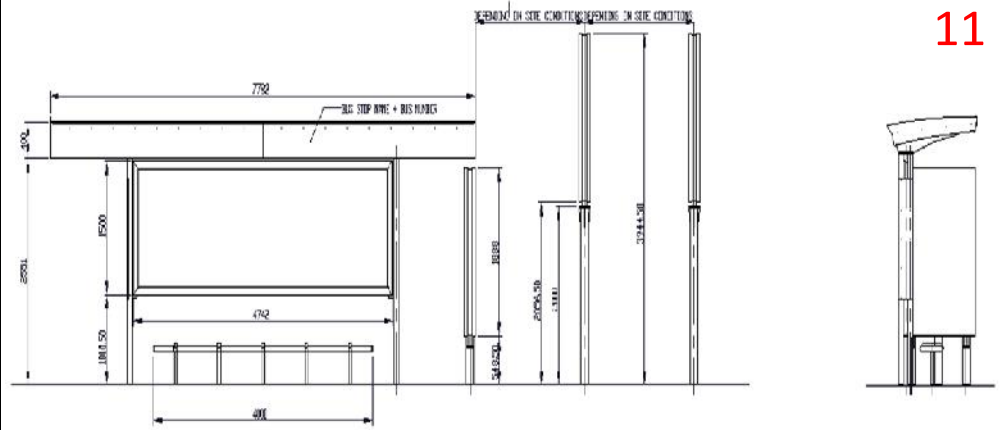

	MUMBAI METROPOLITAN REGION DEVELOPMENT AUTHORITY
	TECHNICAL SPECIFICATIONS AND DETAILS OF STREET FURNITURE (SF) – BUS Q SHELTER
Appendix- XI	Drawings not to scale. All dimensions in mm . Strictly follow written dimensions only
<p>NOTE: The Alternatives are indicative and for reference purpose only and shall act as minimum set benchmark. The bidders shall submit better design in the BID and the SF SPECS proposed by the bidder shall fulfill minimum SPECS mentioned in the adjoining Table. The above SF designs are patented to the companies and are erected in New Delhi and the bidders are prohibited to use these in this BID unless they possess valid copyright and patent certification from the parent company. MMRDA shall stand indemnified to this effect.</p>	

SPECIFICATIONS

TREE GUARD

a	Functional	<ul style="list-style-type: none"> The tree guard shall be of mildsteel or cast iron with finished hot dip Galvanised as standard, can be polyester powder coated to any RAL & BS colour. All grill of medium duty mild steel are supporting frame supplied in two halves.
b	Maintainability	<ul style="list-style-type: none"> The furniture shall be maintained using soap water with pressured pump for washing. The tree guard metal parts shall be coated for protection in case found damaged.
c	Vandalism-proof	<ul style="list-style-type: none"> The tree guard shall not be fragile and safely secured to its foundation
d	Security & Safety considerations	<ul style="list-style-type: none"> The foundation used shall be designed in order to take loads of tree and other factors There shall be no sharp edges visible or reachable by citizens, The grill system shall fix directly into the supporting frame with security fixings.
e	Durability	<ul style="list-style-type: none"> The parts used shall be of steel for better durability. All the steel parts shall be HDG – Hot dip galvanized powder coated to give longer life and better quality.
f	Aesthetics	<ul style="list-style-type: none"> Look shall be simple and well designed to gel with the existing look of the city
g	Co-ordinated design of the various items	<ul style="list-style-type: none"> All tree guards shall be of uniform shape, size, color on the same width of the road.
h	Modularity	<ul style="list-style-type: none"> The design shall be uniform and scalable.
i	Environment considerations	<ul style="list-style-type: none"> All materials shall be recyclable
j	Disable Friendliness	<ul style="list-style-type: none"> This furniture shall be very disabled friendly.
k	Innovativeness	<ul style="list-style-type: none"> The design shall be state of the art and befitting the built form of BKC. The design shall be original and creative.

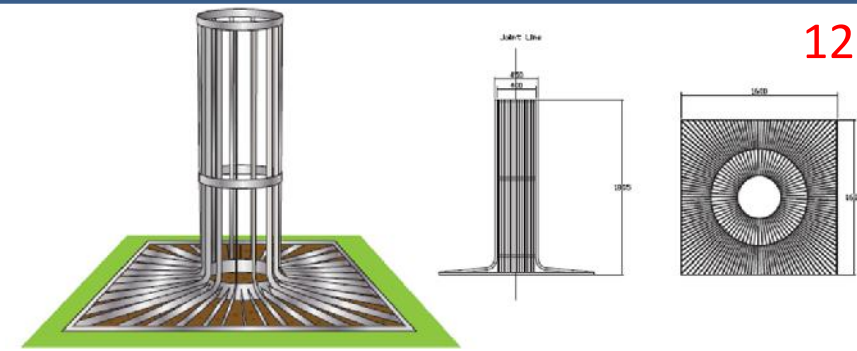

ALTERNATIVE - 1

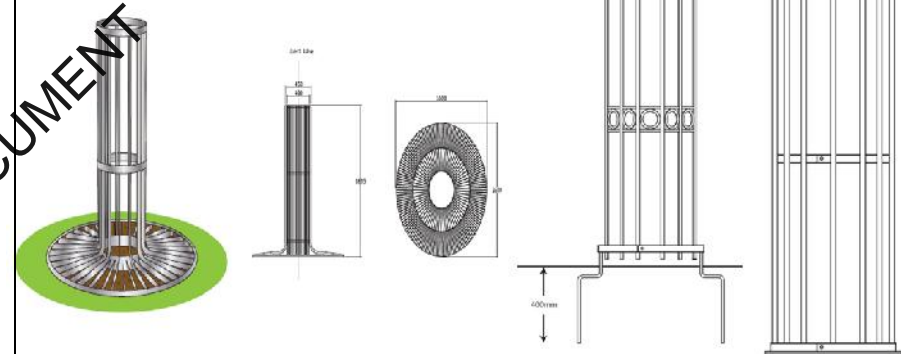

ALTERNATIVE - 2

	MUMBAI METROPOLITAN REGION DEVELOPMENT AUTHORITY
	TECHNICAL SPECIFICATIONS AND DETAILS OF STREET FURNITURE (SF) – TREE GUARD
Appendix- XII	Drawings not to scale. All dimensions in mm . Strictly follow written dimensions only
<p>NOTE: The Alternatives are indicative and for reference purpose only and shall act as minimum set benchmark. The bidders shall submit better design in the BID and the SF SPECS proposed by the bidder shall fulfill minimum SPECS mentioned in the adjoining Table. The above SF designs are patented to the companies and are erected in New Delhi and the bidders are prohibited to use these in this BID unless they possess valid copyright and patent certification from the parent company. MMRDA shall stand indemnified to this effect.</p>	

SPECIFICATIONS BICYCLE STAND

a	Functional	<ul style="list-style-type: none"> The cycle stand shall be of mildsteel or cast iron with finished hot dip Galvanised as standard, can be polyester powder coated to any RAL & BS colour. All stand of medium duty mild steel with supporting frame.
b	Maintainability	<ul style="list-style-type: none"> The furniture shall be maintained using soap water with pressured pump for washing. The cycle stand metal parts shall be coated for protection in case found damaged.
c	Vandalism-proof	<ul style="list-style-type: none"> The cycle stand shall not be fragile and safely secured to its foundation
d	Security & Safety considerations	<ul style="list-style-type: none"> The foundation used shall be designed in order to take loads of pedestrians, parked cycles and other factors There shall be no sharp edges visible or reachable by citizens,
e	Durability	<ul style="list-style-type: none"> The parts used shall be of steel for better durability. All the steel parts shall be HDG – Hot dip galvanized powder coated to give longer life and better quality. The Foundation slab shall be made in min M25 concrete. The cast iron , nuts bolts , shall be rust proof , deep galvanized , powder coated etc . The stainless steel shall be treated to be resistant in all weathers.
f	Aesthetics	<ul style="list-style-type: none"> Look shall be simple and well designed to gel with the existing look of the city
g	Co-ordinated design of the various items	<ul style="list-style-type: none"> All cycle stand shall be of uniform shape, size, color on the same width of the road.
h	Modularity	<ul style="list-style-type: none"> The design shall be uniform and scalable.
i	Environment considerations	<ul style="list-style-type: none"> All materials except fibre glass be recyclable
j	Disable Friendliness	<ul style="list-style-type: none"> This furniture shall be very disabled friendly.
k	Innovativeness	<ul style="list-style-type: none"> The design shall be state of the art and befitting the built form of BKC. The design shall be original and creative.

MMRDA has newly developed a cycle track of 12KM in BKC and wish to operate the cycles on this track. The agency shall have to provide and operate bicycle stands and cycles catering the users of the area. Agency may display the advt. on cycle stand/shelter not exceeding 12 Sq.M. per stand. The cycle stand shall have the racks to dock the cycles with locking facility. Agency shall not charge the public any rentals, etc. for use of the cycles. The agency shall have to maintain the cycles, cycle stands and the cycle track for whole concession period. For first year, the agency shall provide 100 cycles. In second year, another 100 cycles shall be provided by the agency. Similarly, another 100 cycles in third year shall be added to achieve a goal of operating 300 cycles at the specified locations. The Agency shall consider different classes of users.

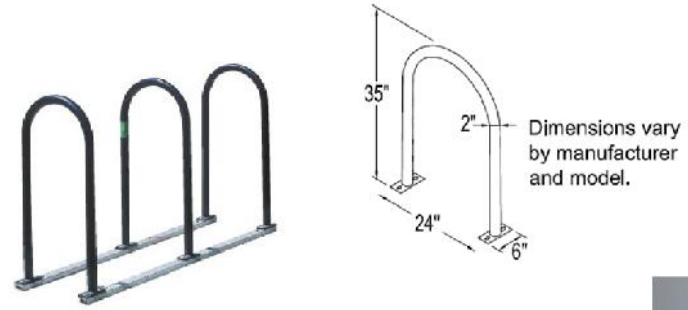

ALTERNATIVES

	MUMBAI METROPOLITAN REGION DEVELOPMENT AUTHORITY
	TECHNICAL SPECIFICATIONS AND DETAILS OF STREET FURNITURE (SF) – BICYCLE STAND
Appendix- XIII	Drawings not to scale. All dimensions in mm . Strictly follow written dimensions only
<p>NOTE: The Alternatives are indicative and for reference purpose only and shall act as minimum set benchmark. The bidders shall submit better design in the BID and the SF SPECS proposed by the bidder shall fulfill minimum SPECS mentioned in the adjoining Table. The above SF designs are patented to the companies and are erected in New Delhi and the bidders are prohibited to use these in this BID unless they possess valid copyright and patent certification from the parent company. MMRDA shall stand indemnified to this effect.</p>	

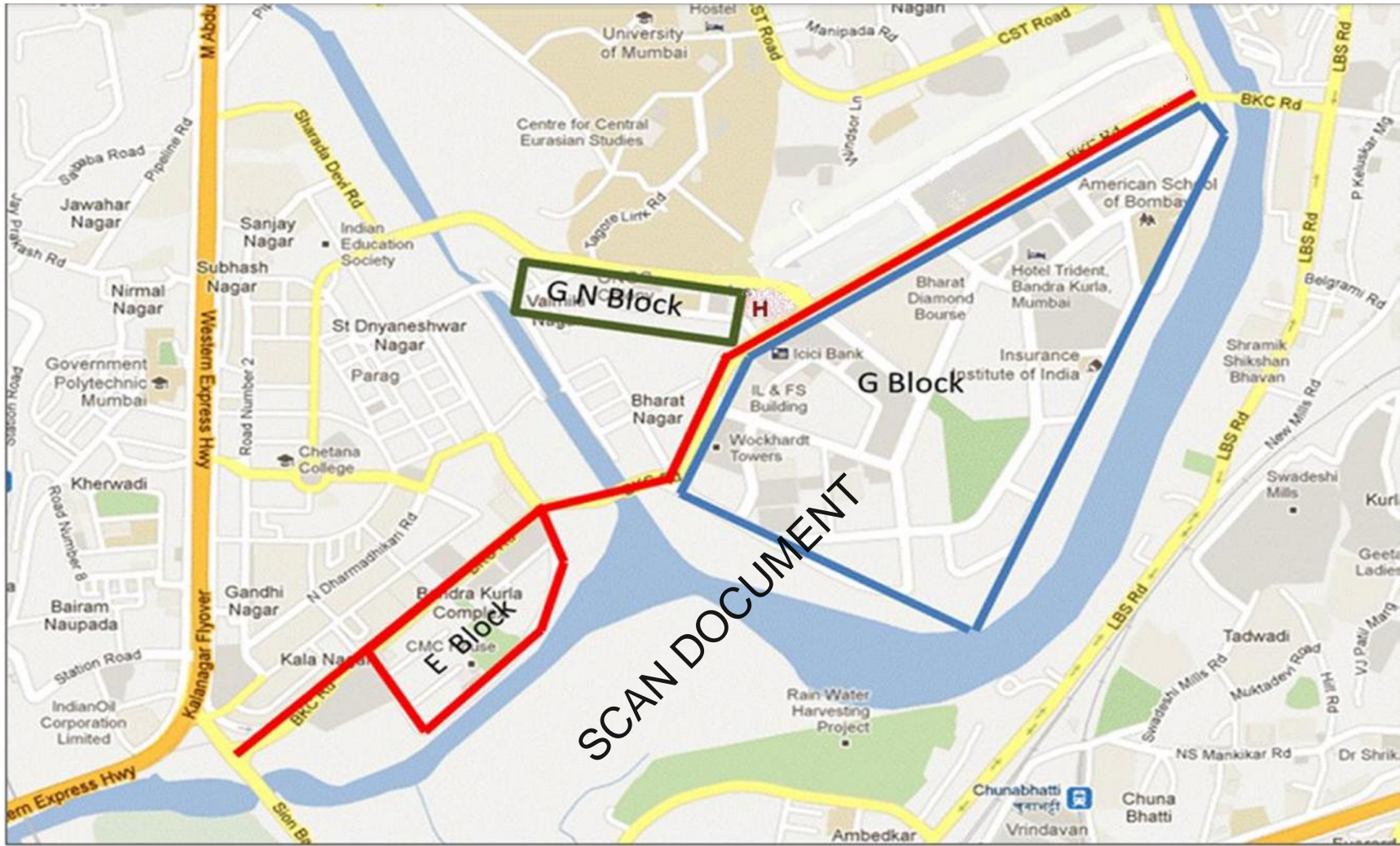

SCAN DOCUMENT

Phase I – E block & 45 M road in G block
Phase II – Balance roads in G block

	MUMBAI METROPOLITAN REGION DEVELOPMENT AUTHORITY
	ERECTION OF STREET FURNITURE IN BKC- IMPLEMENTATION PHASING PLAN
Appendix- XIII	Drawings not to scale. All dimensions in mm . Strictly follow written dimensions only
<p>NOTE: The Alternatives are indicative and for reference purpose only and shall act as minimum set benchmark. The bidders shall submit better design in the BID and the SF SPECS proposed by the bidder shall fulfill minimum SPECS mentioned in the adjoining Table. The above SF designs are patented to the companies and are erected in New Delhi and the bidders are prohibited to use these in this BID unless they possess valid copyright and patent certification from the parent company. MMRDA shall stand indemnified to this effect.</p>	

STREET FURNITURE SUMMARY

Sr. no.	Street Furniture Item	Quantity	Tentative location as per drawing (Symbol)
1	Bench	169	
2	Litter bin	178	
3	Information Board	18	
4	Direction Board	182	
5	Multifunction Booth	17	
6	Flag Pole	50	
7	Vending Kiosk	08	
8	Public Convenience	07	
9	Bollard	1000	
10	Pole Mounted CJP	41	
11	Bus Queue Shelter	29	
12	Tree Guard	Min. 1000	
13	Bicycle Stand	7	

Sr. no.	Block	Junction	Road Length (M)	Road Width (M)
1	G	2-14-20-12	1897.1	45
2		1-2	385.6	30
3		2-13-3	335.8	30
4		3-4	371.55	24
5		4-5	345.7	30
6		5-16-15-14	527.5	24
7		13-15	319.71	24
8		3-6-7-8	1285.95	30
9		6-11-7	601.2	24
10		10-11	601.95	24
11		11-11a-11b	1665.35	18
12		8-24-25	926.3	30
13		19-20	401.4	30
14		5-9	638.1	30
15		12-9-8	302.6	30
16		26-27	213.5	30
17		21-22-23	360.35	18
18		16-16a-15	753.25	18
19		17-18	289.95	18
TOTAL LENGTH			12222.86	25
20	GN	28-32	525.45	25
21		33-34	753.25	15
22		35-36	289.95	30
TOTAL LENGTH			1568.65	30

LIST OF BOS

Sr. no.	Bus Stop Name
1	MMRDA Pay N Park
2	MMRDA Pay N Park
3	MCA Complex
4	Laxmi Tower
5	Canara Bank
6	Canara Bank
7	Dena Bank / Naman centre
8	Dena Bank / Naman centre
9	Bank of India / SBI
10	Bank of Baroda Jn
11	Bank of Baroda Jn
12	Citi Bank
13	Citi Bank
14	Hotel Trident
15	Hotel Trident
16	Bank of India / SBI
17	UTI Regional Training Centre
18	Hindustan Petroleum Officer's Ctrs
19	Bharat Diamond Bourse
20	Bharat Diamond Bourse
21	UTI Regional Training Centre
22	Hindustan Petroleum Officer's Ctrs
23	Ambedkar Nagar
24	Ambedkar Nagar
25	Bank of Baroda
26	Bank of Baroda
27	MCA Complex
28	Laxmi Tower
29	ICICI Bank
30	Bank of Baroda Jn



MITHI RIVER

ANNEXURE- E 2

Sr. no.	Block	Junction	Road Length (M)	Road Width (M)
1	E	A/C - B/ B1	506.67	45
2		B - E	630.47	45
3		B-C-F-D	288.84	25
4		D - E	824.78	15
5		C - I	240.30	25
6		F - G	202.71	18
7		J - H	258.75	25
TOTAL LENGTH			2952.52	

STREET FURNITURE SUMMARY

Sr. no.	Street Furniture Item	Quantity	Tentative location as per drawing (Symbol)
1	Bench	50	
2	Litter Bin	50	
3	Information Board	06	
4	Direction Board	20	
5	Multi purpose Booth	05	
6	Flag Pole	NIL	
7	Vending Kiosk	02	
8	Public Convenience	02	
9	Bollard	100	
10	Pole Mounted CIP	10	
11	Bus Queue Shelter	01	
12	Tree Guard	50 (As Actual)	
13	Bicycle Stand	02	

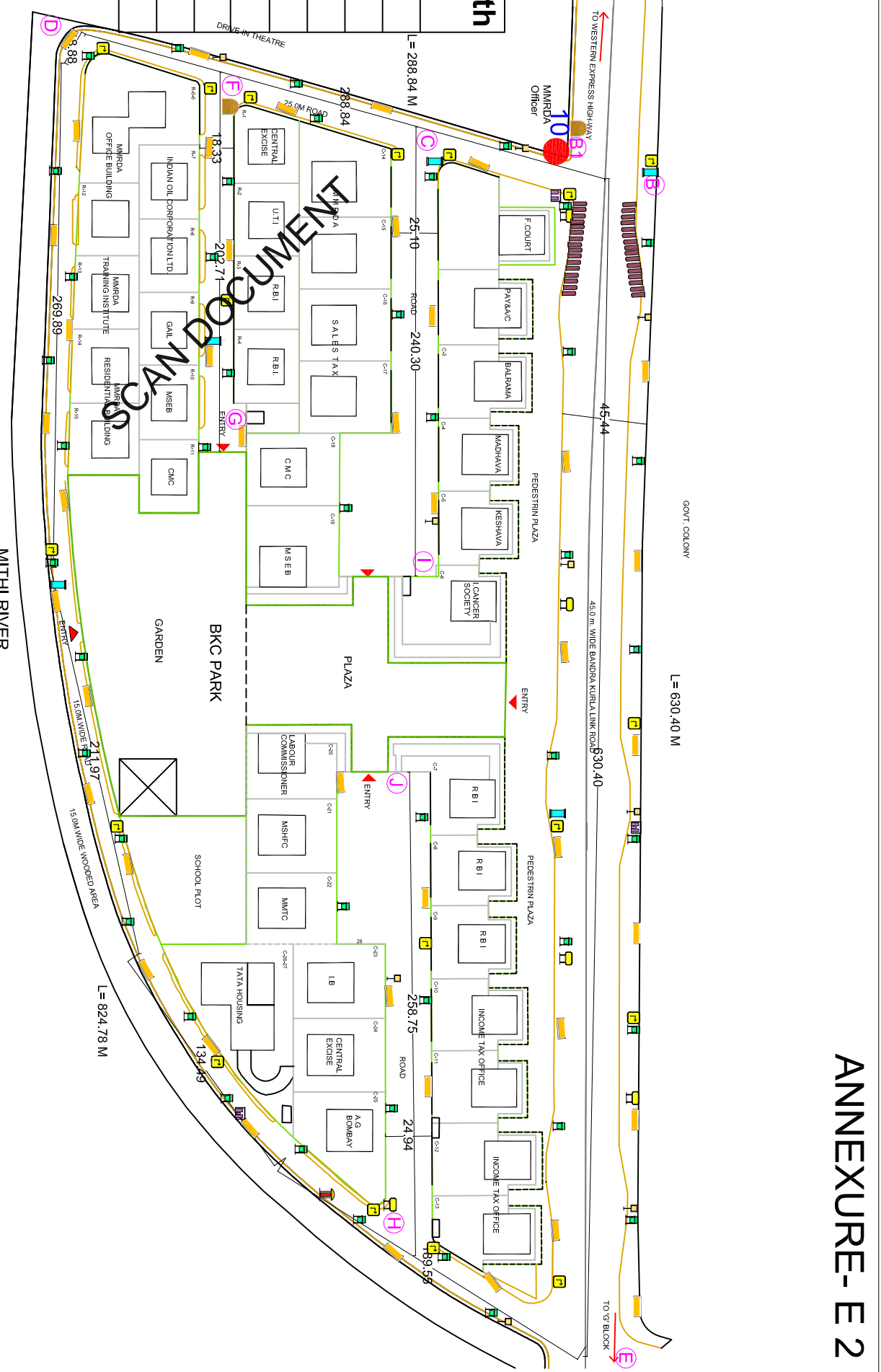

Sr. no.	Bus Stop Name
10	MMRDA Office



**MUMBAI METROPOLITAN REGION
DEVELOPMENT AUTHORITY**

**ERECTION OF STREET FURNITURE IN BKC
STREET FURNITURE PLAN - E BLOCK**

LOCATION OF BUS Q SHELTER

Sr. No.	Bus stop Name	Direction	Route nos.	Location
1	MMRDA Pay N Park	UP	218	Opp. Pay N Park
2	MMRDA Pay N Park	DN	217	O/s Pay N Park
3	M C A Complex	UP	217,218	O/s Maha Cricket Assn Opp Diamond Market, O/s NABARD
4	Laxmi Tower	UP	BKC1, 218	
5	Canara Bank	UP	BKC2,218	Opp Canara bank new Bldg
6	Canara Bank	DN	218	O/s Canara bank new bldg
7	Dena Bank / Naman Centre	UP	218	O/s Dena Bank-inside lane near SIDBI
8	Dena Bank / Naman Centre	DN	218	O/s Raheja Centre-inside lane near SIDBI
9	Bank of India/SBI		BKC2	O/s State Bank of India
10	MMRDA office		218,310	Opp. MMRDA office , Maker Maxity
11	Bank of Baroda Jn	UP	218, BKC2	Opp. to Jn bus stop
12	Citi Bank	UP	BKC1, BKC2	O/s FRB
13	Citi Bank	DN	BKC2	On BKLR
14	Hotel Trident	UP	BKC1, BKC2	Opp. Hotel Trident
15	Hotel Trident	DN	BKC1, BKC2	O/s Hotel Trident
16	Bank of India / SBI	UP	BKC2	O/s NSE, Opp BOI
17	UTI Regional Training Centre	UP	219	O/s UTI Regi. Trng Centre
18	Hindustan Petroleum Officer's Qtrs	DN	219	Opp HPCL's qtrs
19	Bharat Diamond Bourse	UP	BKC1, BKC2	Opp. Diamond Bourse
20	Bharat Diamond Bourse	DN	BKC1, BKC2	O/s Diamond Bourse

Sr. No.	Bus stop Name	Direction	Route nos.	Location
21	UTI Regional Training Centre	DN	219	Opp UTI Regi. Trng Centre
22	Hindustan Petroleum Officer's Qtrs	UP	219	O/S HPCL's qtrs
23	Ambedkar Nagar	UP	219	
24	Ambedkar Nagar	DN	219	
25	Bank of Baroda	UP	No route	Opp Raheja Centre O/s BOB Corporate Bldg
26	Bank of Baroda	DN	No route	
27	MCA Complex	DN	BKC-2,218	
28	Laxmi Tower	DN	218	Opp. NABARD
29	ICICI Bank	UP	BKC1	Bharat Diamond Bourse Gate # 9
30	Bank of Baroda Jn	DN	218, BKC2	Opp. to Jn bus stop

SCAN DOCUMENT

	MUMBAI METROPOLITAN REGION DEVELOPMENT AUTHORITY
	ERECTION OF STREET FURNITURE IN BKC- STREET Location of Bus Q shelters
Appendix- XVI	Drawings not to scale. All dimensions in mm . Strictly follow written dimensions only
NOTE: The Alternatives are indicative and for reference purpose only and shall act as minimum set benchmark. The bidders shall submit better design in the BID and the SF SPECS proposed by the bidder shall fulfill minimum SPECS mentioned in the adjoining Table. The above SF designs are patented to the companies and are erected in New Delhi and the bidders are prohibited to use these in this BID unless they possess valid copyright and patent certification from the parent company. MMRDA shall stand indemnified to this effect.	